



## ELETTRICO

### ELETTRICO

---

SPINOTTI E PRESE DI CORRENTE	426	PLUGS & SOCKETS
CARICABATTERIA 12/24V	441	12/24V CHARGERS
CARICABATTERIA DA RETE	452	HOME CHARGERS
ADATTATORI	454	ADAPTERS
KIT DI RICARICA	455	CHARGING KITS
CAVI	460	CABLES
BATTERIE PORTATILI	472	POWER BANK
TRASFORMATORI E ADATTATORI	476	RECTIFIERS & ADAPTERS
BATTERIA	480	BATTERY
FUSIBILI	501	FUSES
CABLAGGIO ELETTRICO	506	ELECTRICAL WIRING
SEGNALAZIONE	515	SIGNALS
TERMICO	518	THERMAL
TORCE E LAMPADE PORTATILI	525	PORTABLE LAMPS & TORCHES
LUCI SPECIALI	536	SPECIAL LIGHTS



Ø 22 mm  
Foro fissaggio / Hole  
Ø 28/29 mm



**EURO-STYLE, KIT ACCENDISIGARI ILLUMINATO 12V**

Composto da presa illuminata e accendisigari. Con disinnesto automatico

**EURO-STYLE, ILLUMINATED CIGARETTE LIGHTER KIT 12V**

**39070**

D/Blister 10 / 60

IN	12V	Cavo
----	-----	------



Ø 22 mm  
Foro fissaggio / Hole  
Ø 28/29 mm



**EURO-STYLE, PRESA ACCENDISIGARI ILLUMINATA 12V**

Montaggio ad incasso

**EURO-STYLE, ILLUMINATED CIGARETTE LIGHTER SOCKET 12V**

**39071**

D/Blister 10 / 60

IN	12V	Cavo
OUT	12V	Standard



Ø 22 mm



**EURO-STYLE, ACCENDISIGARI 12V**

Universale per la maggior parte delle vetture di produzione europea

**EURO-STYLE, CIGARETTE LIGHTER 12V**

Fits most european cars

**39072**

D/Blister 10 / 60



Ø 21 mm



**A2, ACCENDISIGARI 12V**

Universale per la maggior parte delle vetture di produzione europea e giapponese

**A2, CIGARETTE LIGHTER 12V**

Fits most european and japanese cars.

**39063**

D/Blister 10 / 60



**PRESA ACCENDISIGARI UNIVERSALE 12/24V**  
**UNIVERSAL CIGARETTE LIGHTER SOCKET 12/24V**

IN	12/24 V	Cavo
OUT	12/24 V	Standard

**39060**

D/Blister 10 / 60



Ø 21 mm  
Foro fissaggio / Hole  
Ø 23 mm

**PRESA ACCENDISIGARI 12V ILLUMINATA**  
**ILLUMINATED LIGHTER SOCKET 12V**

IN	12 V	Cavo
OUT	12 V	Standard

**39064**

D/Blister 10 / 60



Ø 21 mm  
Foro fissaggio / Hole  
Ø 23 mm

**KIT ACCENDISIGARI 12V**  
Completo di presa, spinotto e cablaggio,  
con disinnesto automatico quando pronto  
**12V CIGARETTE LIGHTER SET**  
Automatic release when ready

**39065**

D/Blister 10 / 60

Ø 21 mm  
Foro fissaggio / Hole  
Ø 23 mm



IN	12V	Cavo
----	-----	------

**KIT ACCENDISIGARI CON PRESA ILLUMINATA 12V**  
Completo di presa, spinotto e cablaggio  
**12V ILLUMINATED CIGARETTE LIGHTER SET**  
Automatic release when ready

**39066**

D/Blister 10 / 60



Ø 21 mm  
Foro fissaggio / Hole  
Ø 23 mm

IN	12V	Cavo
----	-----	------



**Insettida da acquistarsi separatamente**

**Insect tablets and liquid to be purchased separately**

**Doppia funzione Double function**

**KILLER 2 IN 1, DIFFUSORE ELETTRICO PER INSETTICIDI 12/24V**  
Funziona sia con le tradizionali piastrelle che con le ricariche a liquido insetticida con attacco a vite. Idoneo per l'utilizzo con la maggior parte dei prodotti insetticidi in commercio. Reclinabile, completo di fusibile di protezione e LED indicatore di tensione

**ELECTRIC ANTI MOSQUITO DEVICE, 12/24V**  
Cigarette lighter plug with built-in electric diffuser for insect repellents means. Suitable both for standard tablets and for liquid insecticides. With swivel angle and Led light

**39030**

D/Blister 10 / 100



**EXT** SISTEMA COMPONIBILE

**EXT** COMPONENTS SYSTEM

**EXT** SISTEMA COMPONIBILE

**EXT** COMPONENTS SYSTEM



**EXT, ALLOGGIAMENTO SINGOLO**  
Per prese e porte USB della linea EXT

**EXT, SURFACE MOUNT CASE**  
Suitable for EXT series sockets and USB ports

**39008**

D/Blister 25 / 100

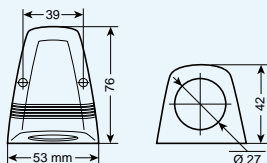

**EXT, ALLOGGIAMENTO DOPPIO**  
Per prese e porte USB della linea EXT

**EXT, DOUBLE SURFACE MOUNT CASE**  
Suitable for EXT series sockets and USB ports

**39009**

D/Blister 25 / 100

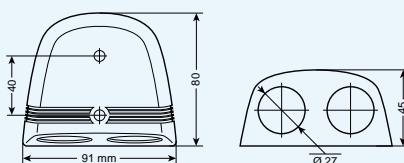

**EXT, PANNELLO DOPPIO**  
Per prese e porte USB della linea EXT

**EXT, TWIN BOARD**  
Suitable for EXT series sockets and USB ports

**39010**

D/Blister 25 / 100

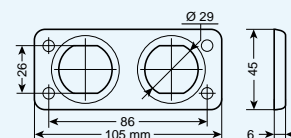

**EXT-9, VOLTMETRO DIGITALE, 6/30V**

Misura la tensione della batteria.  
Montaggio ad incasso.  
Precisione digitale con decimale

**EXT-9, DIGITAL BATTERY  
VOLTMETER, 6/30V**  
Measures the battery voltage.  
Built-in fixing system.  
Digital precision with decimal

**38974**

D/Blister 25 / 100

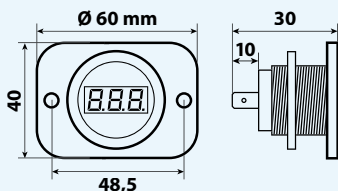

**EXT-11, INTERRUOTORE STACCA  
BATTERIA A 3 POSIZIONI, 12/32V**

Interrompe il circuito elettrico  
principale. Preserva la batteria  
durante il rimessaggio. Efficace  
azione di sicurezza ed antifurto.  
Foro Ø 29 mm. 100A max

**EXT-11, POWER-OFF SWITCHER,  
3 FUNCTIONS, 12/32V**  
Interrupts the main electric circuit.  
Preserves the battery during long  
periods of storage. Safety and  
antitheft action with  
removable selector. Hole Ø 29 mm.  
100A max

**39081**

D/Blister 25 / 100

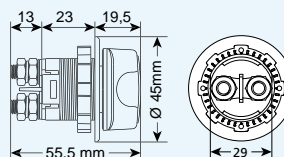
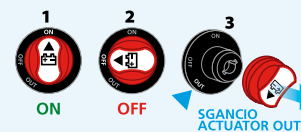

**SPINOTTO SAFE LOCK, 12/24V**

Sistema di bloccaggio anti-  
vibrazione. Utilizzabile solo con  
le prese di corrente della serie  
Safe lock socket tipo Engel-Type  
(max 15A)

**SAFE LOCK PLUG, 12/24V**  
Plug with special anti-vibration  
lock system.  
Suitable for all "Safe lock" or  
Engel-type sockets (max 15A)

**38976**

D/Blister 25 / 100



**ENGEL TYPE**



<b>IN</b>	12/24V	Engel Type
<b>OUT</b>	Morsetti	15 A

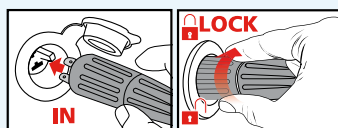
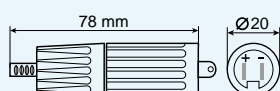

**EXT-10, PRESA DI CORRENTE  
SAFE LOCK, 12/24V**

Sistema di bloccaggio antivibrazione.  
Montaggio ad incasso, utilizzo  
interno o esterno. Impermeabile, con  
coperchio di protezione.  
Idoneo per spinotti Safe lock o tipo  
Engel-type (max 15A)

**EXT-10, SAFE LOCK SOCKET, 12/24V**  
Flush mount socket with special  
anti-vibration lock system. Internal  
and external use. Waterproof, with  
protection cover. Suitable for Safe  
Lock or Engel-Type plugs (max 15A)

**38977**

D/Blister 25 / 100

<b>IN</b>	12/24V	Faston
<b>OUT</b>	12/24V	Engel 15 A

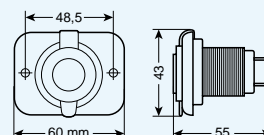

**EXT** SISTEMA COMPONIBILE

**EXT** COMPONENTS SYSTEM

**EXT** SISTEMA COMPONIBILE

**EXT** COMPONENTS SYSTEM

**EXT-1, PRESA CORRENTE, MONTAGGIO AD INCASSO, 12/24V**

Per uso esterno o interno, con coperchio di chiusura

**EXT-1, FLUSH MOUNT SOCKET, 12/24V**  
Suitable for interior or exterior fitment. Dustproof cover

**39036**

D/Blister □ 25 / 100

<b>IN</b>	12/24 V	Faston	
<b>OUT</b>	12/24 V	Standard	20 A

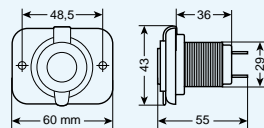

**EXT-6, PRESA CORRENTE DIN, MONTAGGIO AD INCASSO, 12/24V**

Per uso esterno o interno, con coperchio di chiusura

**EXT-6, DIN FLUSH MOUNT SOCKET, 12/24V**  
Suitable for interior or exterior fitment. Protection cover

**39007**

D/Blister □ 25 / 100

<b>IN</b>	12/24 V	Faston	
<b>OUT</b>	12/24 V	DIN	20 A

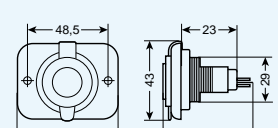

**EXT-7, PRESA USB, MONTAGGIO AD INCASSO, 12/24V**

Per uso esterno o interno, con coperchio di chiusura

**EXT-7, FLUSH MOUNT USB PORT, 12/24V**  
Suitable for interior or exterior fitment. Dustproof cover

**39006**

D/Blister □ 25 / 100

<b>IN</b>	12/24 V	Faston	
<b>OUT</b>	1 x 5 V	USB	2,1 A

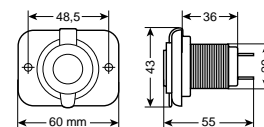

**EXT-8, DOPPIA PRESA USB, MONTAGGIO AD INCASSO, 12/24V**

Per uso esterno o interno, con coperchio di chiusura

**EXT-8, FLUSH MOUNT DOUBLE USB PORT, 12/24V**  
Suitable for interior or exterior fitment. Protection cover

**39005**

D/Blister □ 25 / 100

<b>IN</b>	12/24 V	Faston	
<b>OUT</b>	2 x 5 V	USB	2,1 A tot.

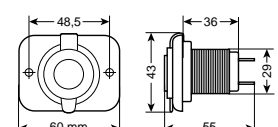

**EXT-3, PRESA CORRENTE IMPERMEABILE, MONTAGGIO IN SUPERFICIE, 12/24V**

Per uso esterno o interno, con coperchio di chiusura

**EXT-3, SURFACE MOUNT WATERPROOF SOCKET, 12/24V**  
Suitable for interior or exterior fitment. Dustproof cover

**39031**

D/Blister □ 25 / 100



<b>IN</b>	12/24 V	Faston	
<b>OUT</b>	12/24 V	Standard	20 A

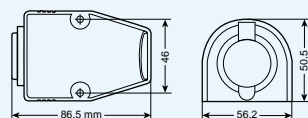

**EXT-2, DOPPIA PRESA CORRENTE, MONTAGGIO AD INCASSO, 12/24V**

Per uso esterno o interno, con coperchi di chiusura

**EXT-2, FLUSH MOUNT DOUBLE SOCKET, 12/24V**  
Suitable for interior or exterior fitment. Dustproof cover

**39037**

D/Blister □ 10 / 100



<b>IN</b>	12/24 V	Faston	
<b>OUT</b>	2 x 12/24 V	Standard	20 A tot.

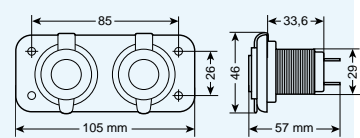



**SPINOTTO STANDARD PER PRESA ACCENDISIGARI 12/24V**  
**STANDARD CIGARETTE LIGHTER PLUG 12/24V**

**39050**

D/Blister □ 24 / 432

IN	12/24V	Standard	
OUT	Morsetti		10 A



**SPINOTTO UNIVERSALE PER PRESA ACCENDISIGARI, 12/24V**  
 Fusibile di protezione e led indicatore di tensione

**UNIVERSAL CIGARETTE LIGHTER PLUG, 12/24V**

Fuse protection. Led indicator light

**39053**

D/Blister □ 25 / 100

IN	12/24 V	Universal	
OUT	Morsetti		15 A



**SICURO, SPINOTTO PER PRESA ACCENDISIGARI 12/24V**

Con fusibile interno e led di segnalazione  
**SICURO, CIGARETTE LIGHTER PLUG 12/24V**

With safety fuse and led

**39051**

D/Blister □ 6 / 288

IN	12/24 V	Standard	
OUT	Cavo 5 cm		10 A



**Interruttore Switch**



**SPINOTTO UNIVERSALE PER PRESA ACCENDISIGARI - 12/24V**  
 Con Interruttore on/off e fusibile di protezione

**UNIVERSAL CIGARETTE LIGHTER PLUG - 12/24V**

With on/off switch and built-in fuse

**38973**

D/Blister □ 10 / 120

IN	12/24 V	Universal	
OUT	Morsetti		10 A



**SPINOTTO DIN PER PRESA ACCENDISIGARI, 12/24V**  
**DIN CIGARETTE LIGHTER PLUG, 12/24V**

**39027**

D/Blister □ 10 / 100

IN	12/24 V	DIN	
OUT	Morsetti		15 A



**SPINOTTO PER PRESA ACCENDISIGARI CON ATTACCO RAPIDO, 12/24V**

Spia di corrente a led.  
 Fusibile di protezione

**CIGARETTE LIGHTER PLUG, 12/24V**

Fuse protection.  
 Led indicator light

**39043**

D/Blister □ 10 / 100

IN	12/24 V	Standard	
OUT	Morsetti		7,5 A



**Interruttore ON-OFF Switch**



**SPINOTTO PER PRESA ACCENDISIGARI CON INGRESSO CAVO LATERALE, 12/24V**

Interruttore on/off con spia a Led verde. Con fusibile

**CIGARETTE LIGHTER PLUG WITH SIDE WIRE CONNECTION, 12/24V**

On/off switch with green Led light. With fuse

**39003**

IN	12/24V	Standard	
OUT	Morsetti		10 A

D/Blister 10 / 100



**SPINOTTO PER PRESA ACCENDISIGARI CON ATTACCHI A MORSETTO, 12/24V**

Doppio collegamento: tramite connettori a banana oppure con cavo diretto. Con fusibile

**CIGARETTE LIGHTER PLUG WITH QUICK CONNECTORS, 12/24V**

Double connection: with banana plugs or direct wire. With fuse

**39004**

IN	12/24V	Standard	
OUT	Connettore / Morsetto		10 A

D/Blister 10 / 100



**SPINOTTO STANDARD PER PRESA ACCENDISIGARI CON CAVO - 12/24V**

Con fusibile interno

**STANDARD CIGARETTE LIGHTER PLUG WITH CABLE - 12/24V**

With internal fuse

**98091**

IN	12/24V	Standard	
OUT	Cavo 120 cm		10 A

D/Blister 10 / 120



**SPINOTTO UNIVERSALE PER PRESA ACCENDISIGARI CON CAVO - 12/24V**

**UNIVERSAL CIGARETTE LIGHTER PLUG WITH CABLE - 12/24V**

**98130**

IN	12/24V	Universal	
OUT	Cavo 200 cm		5 A

D/Blister 10 / 120



**Interruttore Switch**



**SPINOTTO PER PRESA ACCENDISIGARI CON FUSIBILE ESTERNO - 12/24V**

Con interruttore

**CIGARETTE LIGHTER PLUG WITH EXTERNAL FUSE - 12/24V**

On/off switch. Universal

**98090**

IN	12/24V	Universal	
OUT	Cavo 100 cm		10 A

D/Blister 10 / 120



**B-LOCK, SPINOTTO PER PRESA ACCENDISIGARI CON FUNZIONE DI BLOCCAGGIO - 12/24V**

Con fusibile interno

**B-LOCK, PLUG WITH TWIST-LOCK FUNCTION - 12/24V**

With internal fuse and cable

**98092**

IN	12/24V	Standard	
OUT	Cavo 120 cm		10 A

D/Blister 10 / 120



IP65

Ø 22 mm  
Foro fissaggio / Hole  
Ø 28/29 mm



**PRESA CORRENTE STANDARD, MONTAGGIO AD INCASSO, 12/24V**

Con coperchio di protezione IP65. Max 10A

**FLUSH MOUNT BUILT-IN STANDARD SOCKET, 12/24V**

With protection cap. IP65. Max 10A

**39061**

D/Blister 10 / 60

IN	12/24 V	Faston	
OUT	12/24 V	Standard	10 A max



**ALLUMINIO ANODIZZATO**  
ANODIZED ALUMINIUM

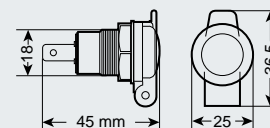

**PRESA CORRENTE DIN IN ALLUMINIO, MONTAGGIO AD INCASSO, 12/24V**

In alluminio anodizzato. Con coperchio di protezione

**FLUSH MOUNT, BUILT-IN ALUMINIUM DIN SOCKET, 12/24V**

Anodize aluminium. With protection cap

**39132**

Blister 10 / 100

IN	12/24 V	Faston	
OUT	12/24 V	DIN	16 A



**POWER-LEAD, PRESA CORRENTE CON PROLUNGA E AVVOLGITORE, 12V**

Spinotto con fusibile di protezione. Interruttore on/off con spia a led. Cavo da 3 metri. 5A max (cavo avvolto) - 10A max (cavo estratto)

**POWER-LEAD, EXTENSION LEAD WITH RETRACTABLE STORAGE REEL, 12V**

Portable power. With fuse, switch, and power-on led. 3 meters cable

**39038**

D/Blister 10 / 60



IN	12 V	Standard	
OUT	12 V	Standard	10 A max
Cavo	300 cm		

**PRESA CORRENTE CON PROLUNGA, 12/24V**

Con coperchio di protezione. Spinotto con fusibile incorporato e led indicatore di tensione.

**SPIRAL EXTENSION CORD WITH PLUG AND SOCKET 12/24V**

**39055**

D/Blister 6 / 48



IN	12/24 V	Standard	
OUT	12/24 V	Standard	10 A max
Cavo	400 cm		





IN	12/24V	DIN	
OUT	12/24V	Standard	8 A

**ADATTATORE PRESA CORRENTE, 12/24V**  
 Ingresso: spinotto DIN - Uscita: spinotto standard.  
 Con coperchio di chiusura. Per collegare  
 apparecchiature 12 o 24V dotate di spinotto tipo  
 accendisigari. Max 8A.

**POWER PLUG ADAPTER, 12/24V**  
 Input: DIN plug - Output: standard plug.  
 Max 8A. Dustproof cover

**39028**

D/Blister 10 / 50



**Snodabile  
Adjustable**



**PRESA CORRENTE SNODABILE  
120°, 12/24V**  
 8A max, attacco DIN  
**ADAPTER SOCKET, 120°  
SWIVEL JOINT 12/24V**  
 8A max

**39052**

D/Blister 10 / 100



IN	12/24V	DIN	
OUT	12/24V	Standard	8 A

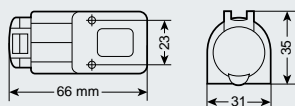

IN	12/24V	Faston	
OUT	12/24V	DIN	15 A

**PRESA CORRENTE DIN,  
MONTAGGIO IN SUPERFICIE, 12/24V**  
 Con coperchio di chiusura. Universale  
**DIN SURFACE MOUNT SOCKET, 12/24V**  
 Complete with cover

**39026**

D/Blister 10 / 100

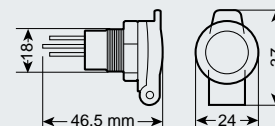

IN	12/24V	Faston	
OUT	12/24V	DIN	16 A

**PRESA CORRENTE MODELLO DIN,  
MONTAGGIO AD INCASSO, 12/24V**  
 Con coperchio di protezione  
**FLUSH MOUNT, BUILT-IN DIN SOCKET,  
12/24V**  
 With protection cap

**39033**

D/Blister 10 / 100

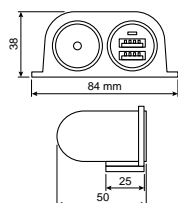

IN	12/24V	Cavo	
OUT	1 x 12/24V	Standard	15 A
	2 x 5V	USB	3 A tot.

**EXTRA-POWER, PRESA CORRENTE  
CON DOPPIA USB, 12/24V**  
 Montaggio in superficie. Indicatore di  
 carica Led. Protezione da sovraccarico.  
 Viti per il fissaggio incluse

**EXTRA-POWER, POWER SOCKET 12/24V  
WITH TWIN USB**  
 Surface mounting. Led indicator.  
 Overload protection. Screws included

**38967**

D/Blister 6 / 36

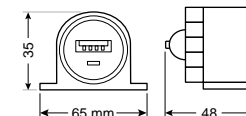

IN	12/24V	Cavo 15 cm	
OUT	1 x 5V	USB	2,1 A

**PRESA USB, 12/24V**  
 Doppia possibilità di fissaggio: da incasso  
 o in superficie. Indicatore di carica a Led.  
 Protezione da sovraccarico.  
 Viti per il fissaggio incluse. Max 2100 mA

**USB PORT, 12/24V**  
 Double fixing system: flush or under-dash  
 mount. Led indicator. Overload protection.  
 Fixing screws included. Max 2100 mA

**38968**

D/Blister 6 / 36



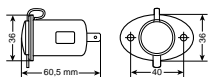

<b>IN</b>	12/24 V	Cavo 90 cm
<b>OUT</b>	12/24 V	Standard   15 A

**KIT PRESA CORRENTE, MONTAGGIO AD INCASSO, 12/24V**

Presca di corrente per montaggio ad incasso predisposta con cablaggio e fusibile di protezione. Coperchio anti-polvere ed accessori di montaggio

**ACCESSORY SOCKET FOR OPTIONAL MOUNTING PANEL, 12/24V**

Complete with dustproof cover and wiring kit

**39034**

D/Blister 25 / 100

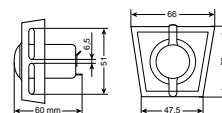

<b>IN</b>	12/24 V	Cavo
<b>OUT</b>	12/24 V	Standard   10 A

**PX-1, KIT PRESA CORRENTE CON PANNELLO DI SUPPORTO OPZIONALE, 12/24V**

Adatta anche per montaggio ad incasso (pannello rimovibile). Completa di coperchio anti-polvere e cablaggi. Biadesivo e viti di fissaggio incluse.

**PX-1, ACCESSORY SOCKET FOR OPTIONAL MOUNTING PANEL, 12/24V**

Complete with dustproof cover and wiring kit

**39035**

D/Blister 25 / 100



<b>IN</b>	12/24 V	Cavo 360 cm
<b>OUT</b>	12/24 V	Standard   15 A

**PX-2, PRESA CORRENTE USO ESTERNO, 12/24V**

Impermeabile. Montaggio fisso o rimovibile

**PX-2, ALL-WEATHER POWER SOCKET, 12/24V**

Waterproof. Permanent or adjustable mount

**38969**

D/Blister 6 / 36

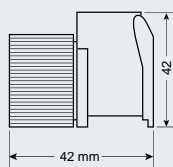

<b>IN</b>	12/24 V	Cavo
<b>OUT</b>	12/24 V	Standard   10 A

**PRESA CORRENTE MONTAGGIO SUPERFICIE 12/24V**

Per uso esterno o interno, completa di coperchio di protezione e base di fissaggio. Viti e connettori rapidi inclusi

**SURFACE-MOUNT CIGARETTE LIGHTER SOCKET 12/24V**

Suitable for interior or exterior fitment. With cover and fitting base. With fitting screws and quick-connector clips.

**39067**

D/Blister 10 / 60



**PRESA CORRENTE CON CLIPS BATTERIA 12/24V**

Con coperchio di protezione

**SOCKET WITH BATTERY CLAMPS 12/24V**

**39057**

D/Blister 12 / 72

<b>IN</b>	12/24 V	Clips
<b>OUT</b>	12/24 V	Standard   10 A



**PRESA CORRENTE DOPPIA 12/24V**  
Con coperchio di protezione  
**PLUG WITH TWO SOCKETS 12/24V**

**39056**

D/Blister 12 / 72

<b>IN</b>	12/24V	Standard	
<b>OUT</b>	2 x 12/24V	Standard	10 A max
<b>Cavo</b>	18 cm		



**PRESA CORRENTE DOPPIA 12/24V**  
Con fusibile e led  
**TWIN LIGHTER SOCKET 12/24V**  
With built-in fuse and led

**39062**

Blister 10 / 80

<b>IN</b>	12/24V	Standard	
<b>OUT</b>	2 x 12/24V	Standard	10 A max



**SILVER, PRESA CORRENTE DOPPIA CON PROLUNGA, 12/24V**  
Fusibile incorporato.  
Fissaggio tramite biadesivo

**SILVER ALUMINIUM DOUBLE SOCKET, 12/24V**  
Fused plug

**39068**

D/Blister 10 / 100

<b>IN</b>	12/24V	Standard	
<b>OUT</b>	2 x 12/24V	Standard	10 A max
<b>Cavo</b>	200 cm		



**PRESA CORRENTE DOPPIA CON PROLUNGA 12/24V**  
Fusibile di protezione. Biadesivo  
**TWIN REMOTE-SOCKETS 12/24V**  
safety fuse. Adhesive

**39054**

D/Blister 6 / 72

<b>IN</b>	12/24V	Standard	
<b>OUT</b>	2 x 12/24V	Standard	10 A
<b>Cavo</b>	250 cm		



**DUAL-MUFFLER, PRESA CORRENTE DOPPIA 12/24V**  
Spinotto con doppia uscita diretta.  
Fusibile incorporato

**DUAL-MUFFLER 12/24V**  
Twin direct sockets exhaust-muffler style with fuse and led

**39080**

D/Blister 6 / 72

<b>IN</b>	12/24V	Standard	
<b>OUT</b>	2 x 12/24V	Standard	10 A max



**PRESA CORRENTE DOPPIA CON PROLUNGA 12/24V**  
Fusibile incorporato. Biadesivo speciale  
**DOUBLE SOCKET 12/24V**  
Fused plug, special tape fitting, led power indicator

**39082**

D/Blister 6 / 72

<b>IN</b>	12/24V	Standard	
<b>OUT</b>	2 x 12/24V	Standard	10 A max
<b>Cavo</b>	200 cm		



# 3 in 1



1 x USB 5V  
Max 1200 mA



1 x 12/24V  
Presa per accendisigari  
Lighter plug

2 x 12/24V  
Presa corrente  
Power socket

## DUO 3+1, PRESA ACCENDISIGARI MULTIPLA CON USB, 12/24V

- 1 presa accendisigari + 2 prese di corrente (max 10 A)
- 1 porta USB (1200 mA max)
- Consente l'utilizzo dell'accendisigari
- Inclinazione regolabile fino a 90°.
- Cavo da 200 cm

## DUO 3+1, MULTI-SOCKET 12/24V + USB

- 1 lighter plug + 2 power sockets.
- 1 USB ports (1200 mA max).
- It allows the use of cigarette lighter.
- Adjustable angle up to 90°.
- 200 cm cable

**39130**

D/Blister 6 / 36



90° - 4 Posizioni

10A max



12-24V



200 cm  
Cavo - Cable

IN	12/24 V	Universal	
OUT	3 x 12/24 V	Standard	10 A tot.
	1 x 5 V	USB	1,2 A
Cavo	200 cm		

# 4 in 1



1 x USB 5V  
Max 1200 mA



1 x 12/24V  
Presa per accendisigari  
Lighter plug

3 x 12/24V  
Presa corrente  
Power socket

## DUO 4+1, PRESA ACCENDISIGARI MULTIPLA CON USB, 12/24V

- 1 presa accendisigari + 3 prese di corrente (10 A max).
- 1 porta USB (1200 mA max).
- Consente l'utilizzo dell'accendisigari.
- Inclinazione regolabile fino a 90°.
- Cavo da 200 cm

## DUO 4+1, MULTI-SOCKET 12/24V + USB

- 1 lighter plug + 3 power sockets (10 A max).
- 1 USB ports (1200 mA max).
- It allows the use of cigarette lighter.
- Adjustable angle up to 90°.
- 200 cm cable

**39131**

D/Blister 6 / 36



90° - 4 Posizioni

10A max



12-24V



200 cm  
Cavo - Cable

IN	12/24 V	Universal	
OUT	4 x 12/24 V	Standard	10 A tot.
	1 x 5 V	USB	1,2 A
Cavo	200 cm		



Coperchio di protezione  
Dustproof cover



Snodabile 120°  
120° Adjustable



## ADATTATORE SNODABILE PER PRESA CORRENTE, 12/24V

Ingresso: spinotto standard - Uscita: spinotto DIN.  
Inclinazione regolabile (120°).  
Con coperchio di chiusura. Max 8A.

## ADAPTER SOCKET, 120° SWIVEL JOINT, 12/24V

Input: standard plug - Output: DIN plug.  
Max 8A. Dustproof cover

**38983**

D/Blister 10 / 120



IN	12/24 V	Standard	
OUT	12/24 V	DIN	8 A max





<b>IN</b>	12/24V	Faston	
<b>OUT</b>	2 x 12/24V	Standard	15 A tot.

**DOPPIA PRESA CORRENTE IMPERMEABILE, MONTAGGIO IN SUPERFICIE, 12/24V**  
Per uso esterno o interno, con coperchio di chiusura. Universale.

**SURFACE MOUNT WATERPROOF DOUBLE SOCKET, 12/24V**  
Suitable for interior or exterior fitment. Dustproof cover

**39029**

D/Blister 10 / 100



**PRESA CORRENTE DOPPIA CON USB - 12/24V**  
Due prese accendisigari con coperchio di protezione e una porta USB. Fusibile di protezione

**DOUBLE SOCKET 12/24V + USB**  
2 lighter sockets with protection cover and 1 USB port. Protection fuse

<b>IN</b>	12/24V	Standard	
<b>OUT</b>	2 x 12/24V	Standard	4 A tot.
	1 x 5V	USB	1 A
<b>Cavo</b>	30 cm		

**38966**

D/Blister 6 / 36



**DUO-4, PRESA CORRENTE DOPPIA CON USB - 12/24V**  
Inclinazione regolabile (0-30-60°)

**DUO-4, DOUBLE SOCKET 12/24V + USB**  
Adjustable angle (0-30-60°)

<b>IN</b>	12/24V	Standard	
<b>OUT</b>	2 x 12/24V	Standard	10 A tot.
	2 x 5V	USB	2 A tot.

**39069**

D/Blister 10 / 60



**PRESA CORRENTE DOPPIA CON PROLUNGA 12/24V**  
Spinotto con fusibile

**DOUBLE SOCKET WITH LED, 12/24V**  
Cable and fused plug

<b>IN</b>	12/24V	Standard	
<b>OUT</b>	2 x 12/24V	Standard	10 A max
<b>Cavo</b>	200 cm		

**39058**

Blister 10 / 80



**CON INTERRUTTORE WITH SWITCH**



**POWER CENTER, PRESA CORRENTE DOPPIA CON USB, 12/24V**  
Con interruttore

**POWER CENTER, DOUBLE SOCKET 12/24V + USB**  
With switch. Fused plug. Surface-mount, easy installation through adhesive tape or screw-on

**39039**

D/Blister 10 / 80

<b>IN</b>	12/24V	Standard	
<b>OUT</b>	2 x 12/24V	Standard	8 A tot.
	2 x 5V	USB	1,2 A tot.
<b>Cavo</b>	150 cm		





2 x 12/24/36V  
max 12A  
Presa corrente  
Car lighter socket

Voltmetro  
Voltmeter

2 x USB 5V  
Max 3100 mA



**MULTI-POWER, 2 PRESE ACCENDISIGARI + 2 USB E VOLTMETRO, 12/24/36V**

Universale, con base adesiva, indicata per auto, camion, imbarcazioni, ecc. Doppia presa multivoltaggio, max 12A, adatta anche per spinotti accendisigari. Doppia porta USB a ricarica rapida (max 3100 mA).

Voltmetro digitale con decimale per monitorare lo stato della batteria e dell'alternatore. Spinotto universale con protezione fusibile. Cavo alimentazione da 80 cm.

**MULTI-POWER, 2 SOCKETS + 2 USB AND VOLTMETER, 12/24/36V**

Universal, with adhesive base, suitable for cars, trucks, boats, etc. Multi-voltage double socket (max 12A) suitable also for cigarette lighter plugs. Quick charge double USB port (max 3100 mA). Digital voltmeter with decimal fraction for instant monitoring of battery conditions and alternator functions. Universal plug with fuse protection and 80 cm power cable.

**38925**

D/Blister 12 / 48

<b>IN</b>	12/24/36V	Universal	
<b>OUT</b>	2 x 12/24/36V	Standard	12 A tot.
	2 x 5V	USB	3,1 A tot.
<b>Cavo</b>	80 cm		



**DUAL-POWER, PRESA CORRENTE TRIPLA CON USB, 12/24V**

- 3 prese corrente (5A max)
- 1 porta USB (2100 mA max)
- Cavo da 90 cm

**DUAL-POWER, MULTI-SOCKET 12/24V + USB**

- 3 power sockets (5A max)
- 1 USB port (2100 mA max)
- 90 cm cable

**39048**

D/Blister 12 / 96



<b>IN</b>	12/24V	Standard	
<b>OUT</b>	3 x 12/24V	Standard	5 A max
	1 x 5V	USB	2,1 A max
<b>Cavo</b>	90 cm		

**Sonda Temperatura Temperature Probe**



**SMART-PLUG, SPINOTTO MULTIFUNZIONE 12/24V**

- Termometro per l'indicazione della temperatura all'interno dell'abitacolo (-9°C/+80°C).
- Voltmetro 12/24V per monitorare la carica della batteria ed il buon funzionamento dell'alternatore.
- Presa USB, 5V, 2100 mA per collegare e caricare qualsiasi apparecchio funzionante tramite presa USB

**SMART-PLUG, MULTI-FUNCTION PLUG 12/24V**

- Interior thermometer for car/truck -9°C/+80°C
- 12/24V battery and alternator tester showing the battery condition and correct operation of the alternator.
- 5V, 2100 mA, USB socket, for connecting and charging any device operating with USB plug

**74063**

D/Blister 10 / 100

<b>IN</b>	12/24V	Standard	
<b>OUT</b>	1 x 5V	USB	2,1 A



**POWER CUP 3 IN 1, PRESA CORRENTE MULTIPLA E TESTER BATTERIA AUTO 12V+USB**

- 2 prese 12V (max 10A) per spinotti tipo accendisigari.
- 2 prese USB 5V (max 500+1000 mA)
- Tester batteria auto a 4 Led.

Cavo alimentazione da 160 cm

**POWER CUP 3 IN 1, MULTIPLE SOCKET AND BATTERY TESTER 12V+USB**

- 2 car lighter sockets 12V (max 10A).
- 2 USB sockets 5V (max 500+1000 mA)
- Car battery tester with 4 led.

160 cm power cable with fused plug

**39040**

D/Blister 10 / 60

Normale 13,8 W	Media 12,8 W	Debole 12 W	Bassa



		<b>500 1000 mA</b>
--	--	----------------------------

<b>IN</b>	12V	Standard	
<b>OUT</b>	2 x 12V	Standard	10 A max
	1 x 5V	USB	0,5 A
	1 x 5V	USB	1,0 A
<b>Cavo</b>	160 cm		



**POWER CUP 2, MULTIPRESA CON USB E TESTER BATTERIA, 12V**

- 2 prese di corrente 12V (max 10A)
- 2 prese USB con circuiti separati (1000+2100 mA)
- Tester batteria a 4 led.
- Spinotto universale, cavo alimentazione da 160 cm
- Si inserisce perfettamente nell'alloggiamento portabicchieri

**POWER CUP 2, POWER SOCKET WITH USB AND BATTERY TESTER, 12V**

- 2 power sockets 12V (max 10A)
- 2 USB ports with separate circuits (1000+2100 mA)
- Battery tester with 4 led.
- Universal plug, 160 cm power cable with fused plug.
- Easy installation, fits into drink holder location

**39011**

D/Blister 10 / 60

Normale 13,8 W	Media 12,8 W	Debole 12 W	Bassa

**POWER LINE**

**1000  
2100  
mA**



Tester Batteria  
Battery Tester

2 x 12V - max 10A  
Presa corrente  
Car lighter socket

USB 1000 mA

CIRCUITI SEPARATI  
USB 2100 mA

12V	5V USB

<b>IN</b>	12V	Standard	
<b>OUT</b>	2 x 12V	Standard	10 A max
	1 x 5V	USB	1,0 A
	1 x 5V	USB	2,1 A
<b>Cavo</b>	160 cm		



4 x USB 5V  
Max 5000 mA

Voltmetro  
Voltmeter

3 x 12/24/36V  
max 12A  
Presa corrente  
Car lighter socket

**EXTRA  
USB  
POWER**

<b>12A max</b>	
12-36V	5V USB

**MULTI-POWER CUP, 3 PRESE ACCENDISIGARI + 4 USB E VOLTMETRO, 12/24/36V**

Universale, inseribile negli alloggiamenti portabicchieri. 3 prese multivoltaggio, max 12A, adatte anche per spinotti accendisigari. 4 porte USB a ricarica rapida (max 5000 mA). Voltmetro digitale con decimale per monitorare lo stato della batteria e dell'alternatore. Spinotto universale con protezione fusibile. Cavo alimentazione da 80 cm.

**MULTI-POWER CUP, 3 SOCKETS + 4 USB AND VOLTMETER, 12/24/36V**

Universal, fits drink-holders. Multi-voltage triple socket (max 12A) suitable also for cigarette lighter plugs. Quick charge quadruple USB port (max 5000 mA). Digital voltmeter with decimal fraction for instant monitoring of battery conditions and alternator functions. Universal plug with fuse protection and 80 cm power cable.

**38926**

D/Blister 12 / 48

<b>IN</b>	12/24/36V	Universal	
<b>OUT</b>	3 x 12/24/36V	Standard	12 A tot.
	4 x 5V	USB	5 A tot.
<b>Cavo</b>	80 cm		



**PRESA CORRENTE TRIPLA CON PROLUNGA 12/24V**  
Spinotto con fusibile

**TRIPLE SOCKET 12/24V**  
Cable and fused plug

**39059**

IN	12/24V	Standard	
OUT	3 x 12/24V	Standard	10 A max
Cavo	200 cm		

D/Blister 10 / 80

**PRESA CORRENTE TRIPLA CON PROLUNGA 12/24V**  
Fusibile incorporato. Biadesivo speciale

**TRIPLE SOCKET 12V/24**  
Fused plug, special tape fitting, led power indicator

**39083**

IN	12/24V	Standard	
OUT	3 x 12/24V	Standard	10 A max
Cavo	200 cm		

D/Blister 6 / 72

**MULTI-SOCKET 4+2, PRESA CORRENTE QUADRUPLA CON USB - 12/24V**  
Con fusibile di protezione

**MULTI-SOCKET 4+2, QUADRUPLE SOCKET 12/24V + USB**  
Protection fuse

**39024**

IN	12/24V	Standard	
OUT	4 x 12/24V	Standard	5 A tot.
	2 x 5V	USB	1 A tot.
Cavo	60 cm		

D/Blister 10 / 40



**HUB-4, PRESA DI CORRENTE MULTIPLA CON USB, 12/24V**  
3 prese di corrente (90W max) e 4 porte Usb (6A totali). Le prese Usb uniscono 2 protocolli di ricarica differenti A e S per garantire la compatibilità con la maggior parte di tablet, smartphone, gps, mp3, ecc. Cavo da 85 cm

**HUB-4, MULTIPLE POWER SOCKET WITH USB, 12/24V**  
3 power sockets (90W max) and 4 Usb ports (6A tot.). This Usb charger with 4 ports combines 2 different charging protocols (port 1-3 / 2-4) to ensure the compatibility with most of tablet, smartphone, gps, mp3. 85 cm cable

**38953**

IN	12/24V	Standard	
OUT	3 x 12/24V	Standard	90W max
	4 x 5V	USB	6 A max
Cavo	85 cm		

D/Blister 5 / 50

**4x5V Totale 6000 mA**

**3x12/24V 90 W Max**



## Tipologie di Caricabatterie - Battery chargers type



### RICARICA STANDARD

**Ricarica standard (5V)**  
Caricatore standard che fornisce sufficiente energia per ricaricare il vostro telefono/smartphone

**Conventional charging (5V)**  
Standard charger that supplies enough energy to charge your phone/smartphone



### FAST CHARGE

**Ricarica veloce universale (5V) fino a due volte più veloce**  
Lo speciale chip riconosce il protocollo di ricarica del dispositivo collegato e fornisce energia ottimale per una ricarica veloce e protetta.

**Universal fast charge (5V) up to 2X faster**  
The special chip recognizes the charging protocol of the connected device and supplies the correct energy for a fast and safe recharge.



### ULTRA FAST CHARGE



**Ricarica veloce adattiva (5-9-12V) fino a 4 volte più veloce**  
per dispositivi con tecnologia Qualcomm® Quick Charge™

**Adaptive fast charge (5-9-12V) up to 4x faster**  
for devices with charging technology Qualcomm® Quick Charge™



**Ricarica veloce universale (5V) fino a 2 volte più veloce**  
per dispositivi con altro sistema di ricarica

**Universal fast charge (5V) up to 2x faster**  
for devices with other charge technology



## FUNZIONI E CARATTERISTICHE FUNCTIONS AND FEATURES



Ricarica Charge



Fusibile Fuse



Torcia Torch



Cavo Cable



Cavo riavvolgibile Rewindable cable



Corrente alimentazione Input power



Compatibilità globale Global compatibility



Interruttore On-Off



Spia Led Led light



Livello carica Charge level



**Protezione batteria da:** corto circuito, surriscaldamento, sovraccarico, sovratensione  
**Battery protection from:** short-circuit, overtemperature, overload, overcurrent

Non esiste alcun tipo di accordo, licenza o legame tra Lampa e Apple o qualsiasi altra azienda proprietaria dei marchi illustrati nel catalogo; i telefoni, le composizioni e le illustrazioni, hanno solo scopo di descrivere l'accessorio, la sua compatibilità e gli attributi fondamentali per la corretta informazione del consumatore. Tutti i marchi, i nomi e i modelli di telefono cellulare sono di proprietà dei rispettivi titolari. iPod, iPhone e iPad sono marchi di Apple Inc, registrati negli Stati Uniti e altri paesi.

There is no agreement, license or business link between Lampa and any phone company/operator or any of the brands shown on the package and catalogue. Photographed compositions and illustrations are intended to properly inform the user about the use and features of the item. All trademarks, names and mobile phone models are the property of the respective companies. iPod, iPhone and iPad are trademarks of Apple inc, registered in the U.S. and other countries.

**ULTRA FAST CHARGE**  
Ricarica ULTRA-RAPIDA

**4x** PIÙ VELOCE FASTER  
**ADAPTIVE FAST CHARGE**  
3,75~18V  
18W MAX



**Qualcomm**  
Quick Charge

**3000 mA** 12-24V LED



CARICABATTERIA  
1 PORTA USB  
1 USB PORT CHARGER  
**38922**

Scatola / Box 10 / 100

**FAST CHARGE**  
Ricarica VELOCE



**2400 mA** 2x PIÙ VELOCE FASTER 12-24V LED



CARICABATTERIA  
1 PORTA USB  
1 USB PORT CHARGER  
**38870**

Scatola / Box 10 / 120

**FAST CHARGE**  
Ricarica VELOCE



**4800 mA** 2x PIÙ VELOCE FASTER 12-24V LED



CARICABATTERIA  
2 PORTE USB  
2 USB PORTS CHARGER  
**38871**

Scatola / Box 10 / 120

**FAST CHARGE**  
Ricarica VELOCE



**7200 mA** 2x PIÙ VELOCE FASTER 12-24V LED



CARICABATTERIA  
3 PORTE USB  
3 USB PORTS CHARGER  
**38872**

Scatola / Box 10 / 120

**FAST CHARGE**  
Ricarica VELOCE



CARICABATTERIA  
4 PORTE USB  
4 USB PORTS CHARGER

**38873**

Scatola / Box 10 / 120



CARICABATTERIA  
3 PORTE USB  
3 USB PORTS CHARGER

**38964**

D/Blister 12 / 120



CARICABATTERIA 1 PORTA USB  
1 USB PORT CHARGER

**39019**

D/Blister 10 / 120



CARICABATTERIA 1 PORTA USB  
1 USB PORT CHARGER

**38957**

D/Blister 10 / 120



**CARIBATTERIA 2 PORTE USB  
2 USB PORTS CHARGER**

**39012**

D/Blister 10 / 120



**DISPLAY 20  
CARIBATTERIA USB  
DISPLAY 20  
1 USB CHARGERS**

**38950**

Scatola / Box 12



20 PZ  
COLORI  
ASSORTITI  
20 PCS  
ASSORTED  
COLORS



**DISPLAY 20  
CARIBATTERIA DOPPIA USB  
DISPLAY 20  
DOUBLE USB CHARGERS**

**38952**

Scatola / Box 10



20 PZ  
COLORI  
ASSORTITI  
20 PCS  
ASSORTED  
COLORS



**DUO-3, PRESA CORRENTE  
CON USB, 12/24V  
DUO-3, LIGHTER PLUG DUAL  
POWER 12/24V + USB**

**39047**

D/Blister 10 / 100

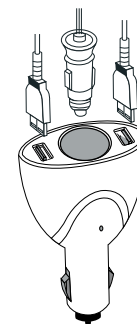

**CARICABATTERIA 1 PORTA USB  
1 USB PORT CHARGER**

**39041**

D/Blister 10 / 100



**CARICABATTERIA 2 PORTE USB  
2 USB PORTS CHARGER**

**39042**

D/Blister 10 / 100



**CARICABATTERIA 2 PORTE USB  
UNIVERSALE**  
Con coperchio protettivo, snodabile  
fino a 90°, spinotto universale  
**UNIVERSAL 2 USB PORTS CHARGER**  
Protective cap, 90° adjustable,  
universal plug

**38975**

D/Blister 25 / 100



**CARICABATTERIA 2 PORTE USB  
UNIVERSALE**  
Con coperchio protettivo  
**UNIVERSAL 2 USB PORTS  
CHARGER**  
Protective cap

**39001**

D/Blister 10 / 100



**CARICABATTERIA UNIVERSALE  
1 PORTA USB  
UNIVERSAL 1 USB PORT CHARGER**

**38879**

Scatola / Box 10 / 100

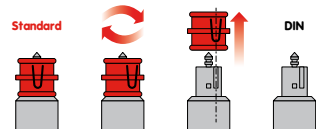

UNIVERSALE  
DIN/STANDARD

**FAST CHARGE**  
Ricarica VELOCE



Confezione double-face  
Double face packaging

**CARICABATTERIA UNIVERSALE  
2 PORTE USB  
UNIVERSAL 2 USB PORTS CHARGER**

**38881**

Scatola / Box 10 / 100

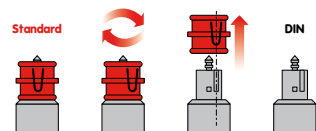

UNIVERSALE  
DIN/STANDARD

**FAST CHARGE**  
Ricarica VELOCE



Confezione double-face  
Double face packaging

**CARICABATTERIA DIN  
1 PORTA USB  
Con coperchio protettivo  
DIN 1 USB PORT CHARGER  
With protective cap**

**38880**

Scatola / Box 10 / 100



Resistente all'acqua  
Water resistant

**FAST CHARGE**  
Ricarica VELOCE



Confezione double-face  
Double face packaging

**CARICABATTERIA DIN  
2 PORTE USB  
Con coperchio protettivo  
DIN 2 USB PORTS CHARGER  
With protective cap**

**38882**

Scatola / Box 10 / 100



Resistente all'acqua  
Water resistant

**FAST CHARGE**  
Ricarica VELOCE



Confezione double-face  
Double face packaging

**CARICABATTERIA 4 PORTE USB**

Inclinazione regolabile fino a 90°. Fusibile esterno da 4A con Led che si accende in caso di guasto

**4 USB PORTS CHARGER**  
Adjustable angle up to 90°, External 4A fuse with Led indicator in case of damage

**38972**

D/Blister 6 / 60



IL FUSIBILE SI ILLUMINA IN CASO DI GUASTI

THE FUSE LIGHT UP IN CASE OF DAMAGE



**CARICABATTERIA 4 PORTE USB**

2 protocolli di ricarica differenti per garantire la compatibilità con la maggior parte dei dispositivi. Inclinazione regolabile fino a 90°.

**4 USB PORTS CHARGER**  
2 different charging protocols to ensure the compatibility with most devices. Adjustable angle up to 90°

**38961**

D/Blister 5 / 50



**CARICABATTERIA 2 PORTE USB CON PROLUNGA**

**2 USB PORTS CHARGER WITH EXTENSION CABLE**

**38965**

D/Blister 10 / 60



**CARICABATTERIA 4 PORTE USB CON PROLUNGA**

Fissaggio tramite adesivo  
**4 USB PORTS CHARGER WITH EXTENSION CABLE**  
Adhesive fixing.

**38962**

D/Blister 5 / 50



**FAMILY USB, CARICABATTERIA  
5 PORTE USB CON PROLUNGA**

- Permette di collegare fino a 5 dispositivi.
- Chip intelligente che riconosce il protocollo del dispositivo collegato e fornisce energia ottimale per una ricarica veloce e protetta.
- 2 prese Usb frontali da 4800 mA e 3 Usb posteriori da 6800 mA (180 cm di cavo) con fissaggio alla tasca posteriore del sedile o bocchetta d'aerazione.
- Protezione da corto circuito, sovraccarico, sovratensione e surriscaldamento.

**FAMILY USB, 5 USB PORTS CHARGER**

- Enables to connect up to 5 devices simultaneously.
- Smart chip that recognizes the charging protocol of the connected device and supplies the correct energy for a fast and safe recharge.
- 2 front Usb 4800 mA and 3 rear Usb 6800 mA (180 cm cable) with fixing for back seat pocker or air vent grill.
- Over voltage, over current, over temperature and short circuit protection.

**38851**

Scatola / Box 5 / 60

**11600 mA**

**2x** PIU VELOCE FASTER

**12-24V**

180 cm



**Doppio Sistema di Fissaggio  
Double Fixing System**

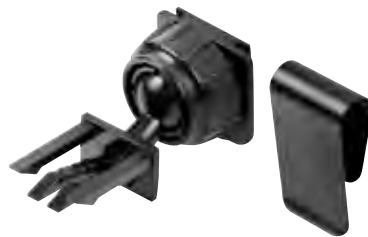

**5 USB**  
**2 USB**  
**3 USB EXTRA**

**FAST CHARGE**  
Ricarica VELOCE

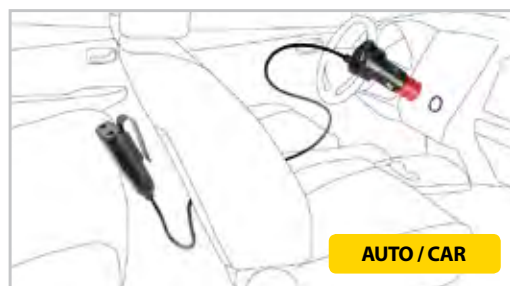

**EXTENDER, CARICABATTERIA  
4 PORTE USB CON PROLUNGA**

**EXTENDER, 4 USB PORTS  
CHARGER**

**38883**

Scatola / Box 10 / 100

**4 USB**  
**2 USB**  
**2 USB EXTRA**

**UNIVERSALE  
DIN/STANDARD**

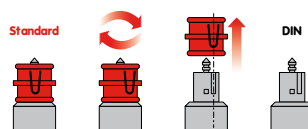

**FAST CHARGE**  
Ricarica VELOCE

**7800 mA**

**2x** PIU VELOCE FASTER

**12-24V**

180 cm



**CARICABATTERIA USB TYPE-C  
CON 1 PORTA USB**  
**USB TYPE-C CHARGER  
WITH 1 USB PORT**

**38892**

Scatola / Box 10 / 120

ALLUMINIO  
ALUMINIUM



ALLUMINIO  
ALUMINIUM

**1 USB TYPE-C  
1 USB EXTRA**



**FAST CHARGE**  
*Ricarica VELOCE*

3000 mA **3X** PIÙ VELOCE FASTER 12-24V LED 150 cm

**CARICABATTERIA LIGHTNING  
CON 1 PORTA USB**  
Connettore originale Apple.  
**LIGHTNING CHARGER  
WITH 1 USB PORT**  
Original Apple connector.

**38927**

Scatola / Box 10 / 120



ALLUMINIO  
ALUMINIUM

**1 Apple LIGHTNING  
1 USB EXTRA**

Made for iPod iPhone iPad



**FAST CHARGE**  
*Ricarica VELOCE*

2400 mA **2X** PIÙ VELOCE FASTER 12-24V LED 150 cm

**CARICABATTERIA MICRO USB  
CON 1 PORTA USB**  
**MICRO USB CHARGER  
WITH 1 USB PORT**

**38928**

Scatola / Box 10 / 120



ALLUMINIO  
ALUMINIUM

**1 MICRO USB  
1 USB EXTRA**



**FAST CHARGE**  
*Ricarica VELOCE*

2400 mA **2X** PIÙ VELOCE FASTER 12-24V LED 150 cm

**CARICABATTERIA MICRO USB  
CON 1 PORTA USB  
MICRO USB CHARGER  
WITH 1 USB PORT**

**38875**

Scatola / Box 10 / 100

**FAST CHARGE**  
Ricarica VELOCE



1 MICRO USB  
1 USB EXTRA

3100 mA 2X PIÙ VELOCE FASTER 12-24V LED 90 cm

**CARICABATTERIA MICRO USB  
CON 2 PORTE USB  
MICRO USB CHARGER  
WITH 2 USB PORTS**

**38874**

Scatola / Box 10 / 120

**FAST CHARGE**  
Ricarica VELOCE



1 MICRO USB  
2 USB EXTRA

ALLUMINIO  
ALUMINIUM

5800 mA 2X PIÙ VELOCE FASTER 12-24V LED 150 cm

**CARICABATTERIA MICRO USB  
CON 2 PORTE USB  
MICRO USB CHARGER  
WITH 2 USB PORTS**

**38963**

D/Blister 10 / 100

**FAST CHARGE**  
Ricarica VELOCE



1 MICRO USB  
2 USB EXTRA

ALLUMINIO  
ALUMINIUM

2400 mA 12-24V LED 150 cm

CARICABATTERIA UNIVERSAL  
CONNECTOR CON 1 PORTA USB  
UNIVERSAL CONNECTOR  
CHARGER WITH 1 USB PORT

1 UNIVERSAL CONNECTOR  
1 USB EXTRA

**38842**

Scatola / Box 10 / 120

UNIVERSAL  
CONNECTOR

Apple  
8 Pin



Micro USB



ALLUMINIO  
ALUMINIUM



2500 mA | 2X PIÙ VELOCE FASTER | 12-24V | LED | 150 cm

**FAST CHARGE**  
Ricarica VELOCE

CARICABATTERIA  
UNIVERSAL CONNECTOR  
CON 2 PORTE USB  
UNIVERSAL CONNECTOR  
CHARGER WITH 2 USB PORTS

1 UNIVERSAL CONNECTOR  
2 USB EXTRA

**38843**

Scatola / Box 10 / 120

UNIVERSAL  
CONNECTOR

Apple  
8 Pin



Micro USB



ALLUMINIO  
ALUMINIUM



5800 mA | 2X PIÙ VELOCE FASTER | 12-24V | LED | 150 cm

**FAST CHARGE**  
Ricarica VELOCE

CARICABATTERIA TYPE-C  
CON 2 PORTE USB  
TYPE-C CHARGER  
WITH 2 USB PORTS

1 USB TYPE-C  
2 USB EXTRA

**38852**

Scatola / Box 10 / 120



ALLUMINIO  
ALUMINIUM



6000 mA | 2X PIÙ VELOCE FASTER | 12-24V | LED | 150 cm

**FAST CHARGE**  
Ricarica VELOCE

**CARICABATTERIA DA RETE CON 1 PORTA USB**

Doppia tecnologia:

- Ricarica veloce universale
  - Qualcomm® Quick Charge™ per i dispositivi abilitati.
- Massima protezione della batteria.  
Compatibilità di voltaggio globale

**HOME CHARGER WITH 1 USB PORT**

Double Technology:

- Universal fast charge.
  - Qualcomm® Quick Charge™ for enabled devices.
- Max battery protection.  
Global voltage compatibility

**38924**

Scatola / Box 10 / 120



**ULTRA FAST CHARGE**  
Ricarica ULTRA-RAPIDA



**CARICABATTERIA DA RETE CON 2 PORTE USB**

Ricarica veloce universale.

Compatibilità di voltaggio globale

**HOME CHARGER WITH 2 USB PORTS**

Universal fast charge.

Global voltage compatibility

**38876**

Scatola / Box 10 / 100



**FAST CHARGE**  
Ricarica VELOCE



**CARICABATTERIA DA RETE CON 1 PORTA USB**

Compatibilità di voltaggio globale.

**HOME CHARGER WITH 1 USB PORT**

Global voltage compatibility

**38948**

Scatola / Box 10 / 120

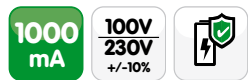

**CARICABATTERIA DA RETE CON 2 PORTE USB**

Compatibilità di voltaggio globale.

**HOME CHARGER WITH 2 USB PORTS**

Global voltage compatibility

**38949**

Scatola / Box 10 / 120



**POWER STATION, CARICABATTERIA DA RETE CON 6 PORTE USB - 230V**

- 7000 mA auto-bilanciati in base alla richiesta dei dispositivi collegati.
- 5 porte Usb ricarica veloce universale + 1 porta Usb con tecnologia Qualcomm Quick Charge 3.0 a ricarica adattiva.
- Massima protezione per il telefono e per la batteria: protezione da sovraccarico e corto circuito.
- Lo speciale chip riconosce il protocollo di ricarica del dispositivo collegato e fornisce energia ottimale per una ricarica veloce e protetta.

**POWER STATION, 6 USB PORTS HOME CHARGER - 230V**

- 7000 mA auto balanced, depending on the need of the connected devices.
- 5 Usb universal fast charge + 1 Usb with Qualcomm Quick Charge 3.0 and adaptive charge.
- Max protection for your phone and battery: over load and short circuit protection.
- The special chip recognizes the charging protocol of the connected device and supplies the correct energy for a fast and safe recharge.

**38946** 82x82x35 mm

Scatola / Box 5 / 60

7000 mA, 100V 230V +/-10%, 100 cm, icons for protection and power



1 m

**FAST CHARGE**  
Ricarica VELOCE

5 + 1

**Qualcomm**  
Quick Charge 3.0

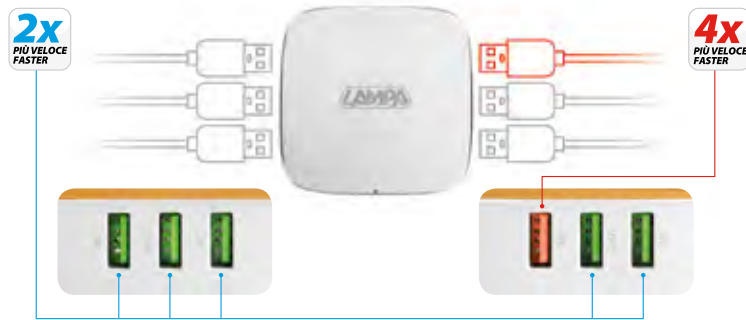

**CARICABATTERIA DA RETE MICRO USB CON 1 PORTA USB**  
Ricarica veloce universale.

Compatibilità di voltaggio globale

**MICRO USB HOME CHARGER WITH 1 USB PORT**

Universal fast charge.  
Global voltage compatibility

**38947**

Scatola / Box 10 / 100

**FAST CHARGE**  
Ricarica VELOCE

2400 mA, 2x PIU VELOCE FASTER, 100V 230V +/-10%, 90 cm, protection icon

1 MICRO USB  
1 USB



**PRESA TRASFORMATORE 230V > 12V**

Trasformatore di corrente da rete 230V che permette di ricaricare dispositivi tramite spinotto accendisigari 12V

**230V > 12V ADAPTOR**  
Connect to the 230V home socket all the 12V electrical devices with cigarette lighter plug

**38951**

Scatola / Box 10 / 100

400 mA, 230V, 12V, icons for power and voltage





# Travel Mate Elite



1x AC  
Adattatore  
Adaptor

2x  
USB

2400 mA  
Fast Charge

max 10A

### TRAVEL MATE ELITE, ADATTATORE UNIVERSALE DA VIAGGIO + CARICATORE USB A 2 PORTE

- Adatto per le prese di tutto il mondo.
- Compatibilità di voltaggio globale.
- Design compatto da portare sempre con te.
- Adattatore per allacciamenti bipolari (senza collegamento a terra).
- Gli adattatori non convertono il voltaggio

### TRAVEL MATE ELITE, UNIVERSAL TRAVEL ADAPTER + 2 PORT USB CHARGER

- Suitable for home plugs worldwide.
- Global voltage compatibility.
- Compact design, to always have it handy.
- Suitable for bipolarity connections (no ground).
- The adapters do not convert voltage

**P15005**

Scatola / Box 5 / 50

## FAST CHARGE

Ricarica VELOCE

2400 mA

2X  
PIU VELOCE  
FASTER

100V  
230V  
+/-10%

LED

Protezione Totale  
Total Protection



Fino a 3 dispositivi  
Up to 3 devices



Compatible:



Laptop



Camera



Mp3



Smartphone  
& Tablet



UK type



EU type



|| USA type  
/\ AUS type



max 10A



# Travel Mate

Adattatori  
Adapters



EU type



UK type

### TRAVEL MATE, SET ADATTATORI UNIVERSALI DA VIAGGIO

- Adatti per le prese di tutto il mondo.
- Design compatto da portare sempre con te.
- Adattatore per allacciamenti bipolari (senza collegamento a terra).
- Gli adattatori non convertono il voltaggio

### TRAVEL MATE, UNIVERSAL PLUG ADAPTERS SET

- Suitable for home plugs worldwide.
- Compact design, to always have it handy.
- Suitable for bipolarity connections (no ground).
- The adapters do not convert voltage

**P15004**

D/Blister 5 / 60



/\ AUS type



|| USA type

USB TYPE-C

KIT 2 IN 1 USB TYPE-C

38894

Scatola / Box 10 / 120

Fino a: / Up to:

480 MB/S

Trasferimento dati  
Data transfer

3000 mA / 18w

Trasferimento corrente  
Power transfer

**ULTRA FAST CHARGE**  
Ricarica ULTRA-RAPIDA



SMARTPHONE/TABLET  
LAPTOP/NOTEBOOK



USB TYPE-C

KIT 2 IN 1 USB TYPE-C

38893

Scatola / Box 10 / 120

Fino a: / Up to:

480 MB/S

Trasferimento dati  
Data transfer

3000 mA

Trasferimento corrente  
Power transfer

**FAST CHARGE**  
Ricarica VELOCE



ALLUMINIO  
ALUMINIUM



MICRO USB

KIT 2 IN 1 MICRO USB

38923

Scatola / Box 10 / 100

Fino a: / Up to:

480 MB/S

Trasferimento dati  
Data transfer

3000 mA

Trasferimento corrente  
Power transfer

**ULTRA FAST CHARGE**  
Ricarica ULTRA-RAPIDA



**MICRO USB**

**KIT 3 IN 1 MICRO USB**

**38877**

Scatola / Box 10 / 100

**FAST CHARGE**  
Ricarica VELOCE

Fino a: / Up to:

**480 MB/S**

Trasferimento dati  
Data transfer

**3000 mA**

Trasferimento corrente  
Power transfer



**2400 mA**

**2X**  
PIU' VELOCE  
FASTER



**100V  
230V  
+/-10%**

**2400 mA**

**2X**  
PIU' VELOCE  
FASTER



**MICRO USB**

**KIT 2 IN 1 MICRO USB**

**38941**

Scatola / Box 10 / 120

**FAST CHARGE**  
Ricarica VELOCE

Fino a: / Up to:

**480 MB/S**

Trasferimento dati  
Data transfer

**3000 mA**

Trasferimento corrente  
Power transfer

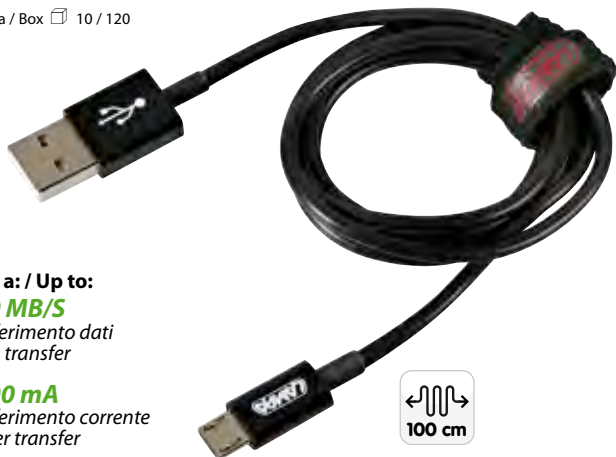

**2400 mA**

**2X**  
PIU' VELOCE  
FASTER



**MICRO USB**

**KIT 3 IN 1 MICRO USB**

**38944**

Scatola / Box 10 / 120

Fino a: / Up to:

**480 MB/S**

Trasferimento dati  
Data transfer

**3000 mA**

Trasferimento corrente  
Power transfer

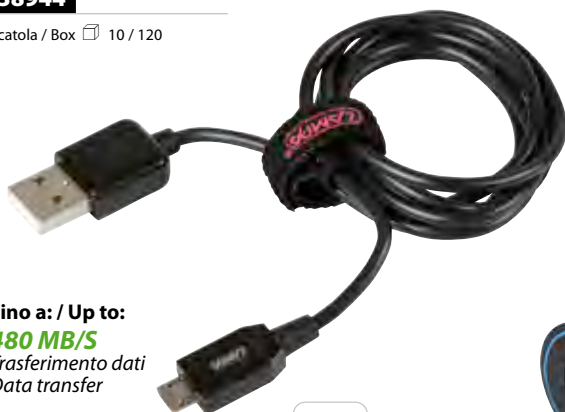

**1000 mA**

**100V  
230V  
+/-10%**



**1000 mA**

**12-24V**





**MICRO USB**

**KIT 2 IN 1 MICRO USB**

**38938**

Scatola / Box 10 / 120



**Fino a: / Up to:**  
**480 MB/S**  
Trasferimento dati  
Data transfer

**3000 mA**  
Trasferimento corrente  
Power transfer



**FAST CHARGE**  
Ricarica VELOCE

**Apple LIGHTNING**

**KIT 3 IN 1 LIGHTNING**

Connettore originale Apple.  
Original Apple connector.

**38943**

Scatola / Box 10 / 120



**Fino a: / Up to:**  
**480 MB/S**  
Trasferimento dati  
Data transfer

**3000 mA**  
Trasferimento corrente  
Power transfer

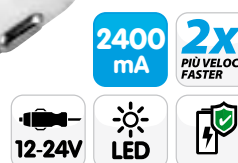
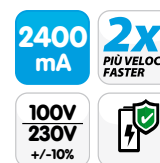

**Apple LIGHTNING**

**KIT 2 IN 1 LIGHTNING**

Connettore originale Apple.  
Original Apple connector.

**38937**

Scatola / Box 10 / 120



**Fino a: / Up to:**  
**480 MB/S**  
Trasferimento dati  
Data transfer

**3000 mA**  
Trasferimento corrente  
Power transfer



**Apple DOCK 30 PIN**

**KIT 2 IN 1 DOCK 30 PIN  
 APPLE**

**38939**

Scatola / Box 10 / 120



**Fino a: / Up to:**  
**480 MB/S**  
*Trasferimento dati*  
*Data transfer*

**3000 mA**  
*Trasferimento corrente*  
*Power transfer*



**Apple DOCK 30 PIN**

**KIT 3 IN 1 DOCK 30 PIN  
 APPLE**

**38945**

Scatola / Box 10 / 100



**Fino a: / Up to:**  
**480 MB/S**  
*Trasferimento dati*  
*Data transfer*

**3000 mA**  
*Trasferimento corrente*  
*Power transfer*



**Samsung DOCK 30 PIN**

**KIT 2 IN 1 DOCK 30 PIN  
 SAMSUNG**

**38940**

Scatola / Box 10 / 100



**Fino a: / Up to:**  
**480 MB/S**  
*Trasferimento dati*  
*Data transfer*

**2400 mA**  
*Trasferimento corrente*  
*Power transfer*



**UNIVERSAL CONNECTOR**

**KIT 2 IN 1  
UNIVERSAL CONNECTOR**

**38844**

Scatola / Box 10 / 120

**Fino a: / Up to:**  
**480 MB/S**  
Trasferimento dati  
Data transfer

**3000 mA**  
Trasferimento corrente  
Power transfer

100 cm

**Collo e cavo rinforzati**  
Reinforced cable and neck

**FAST CHARGE**  
*Ricarica VELOCE*

ALLUMINIO ALUMINIUM

2500 mA  
2X PIU VELOCE FASTER

12-24V LED

**UNIVERSAL CONNECTOR**

Apple 8 Pin

Micro USB

**UNIVERSAL CONNECTOR**

**KIT 3 IN 1  
UNIVERSAL CONNECTOR**

**38845**

Scatola / Box 10 / 120

**Fino a: / Up to:**  
**480 MB/S**  
Trasferimento dati  
Data transfer

**3000 mA**  
Trasferimento corrente  
Power transfer

100 cm

**Collo e cavo rinforzati**  
Reinforced cable and neck

**FAST CHARGE**  
*Ricarica VELOCE*

ALLUMINIO ALUMINIUM

2500 mA  
2X PIU VELOCE FASTER

12-24V LED

1000 mA  
2X PIU VELOCE FASTER

100V 230V +/-10% LED

**USB TYPE-C**

**KIT 3 IN 1 USB TYPE-C**

**38853**

Scatola / Box 10 / 120

**Fino a: / Up to:**  
**480 MB/S**  
Trasferimento dati  
Data transfer

**3000 mA**  
Trasferimento corrente  
Power transfer

100 cm

**FAST CHARGE**  
*Ricarica VELOCE*

3100 mA  
2X PIU VELOCE FASTER

100V 230V +/-10% LED

3000 mA  
2X PIU VELOCE FASTER

12-24V LED



USB TYPE C

Ultra Speed

ULTRA RESISTANT

Fino a: / Up to:  
**480 MB/S**  
Trasferimento dati  
Data transfer

**2400 mA**  
Trasferimento corrente  
Power transfer



**IRON, CAVO RICARICA E SINCRONIZZAZIONE**

Compatibile con ricarica super veloce.  
Rivestimento in metallo per proteggere il cavo e ridurre l'usura.

Struttura in metallo, collo e cavo rinforzati.

**IRON, CHARGE & SYNC CABLE**

Compatible with super fast charge.  
Metal reinforcement to protect the cable and reduce wearing.

Metal frame, reinforced neck and cable.

**38857 100 cm**

Scatola / Box  10 / 120



**ULTRA**  
Resistente  
Resistant

MICRO USB

ULTRA RESISTANT

Fino a: / Up to:  
**480 MB/S**  
Trasferimento dati  
Data transfer

**2400 mA**  
Trasferimento corrente  
Power transfer



**IRON, CAVO RICARICA E SINCRONIZZAZIONE**

Compatibile con ricarica super veloce.  
Rivestimento in metallo per proteggere il cavo e ridurre l'usura.

Struttura in metallo, collo e cavo rinforzati.

**IRON, CHARGE & SYNC CABLE**

Compatible with super fast charge.  
Metal reinforcement to protect the cable and reduce wearing.

Metal frame, reinforced neck and cable.

**38855 100 cm**

Scatola / Box  10 / 120



**ULTRA**  
Resistente  
Resistant

Apple 8 PIN

ULTRA RESISTANT

Fino a / Up to:  
**480 MB/S**  
Trasferimento dati  
Data transfer

**2400 mA**  
Trasferimento corrente  
Power transfer



**IRON, CAVO RICARICA E SINCRONIZZAZIONE**

Compatibile con ricarica super veloce.  
Rivestimento in metallo per proteggere il cavo e ridurre l'usura.  
Struttura in metallo, collo e cavo rinforzati.  
**IRON, CHARGE & SYNC CABLE**  
Compatible with super fast charge.  
Metal reinforcement to protect the cable and reduce wearing.  
Metal frame, reinforced neck and cable.

**38856** 100 cm

Scatola / Box 10 / 120

**ULTRA**  
Resistente  
Resistant



Apple 8 PIN



Fino a / Up to:  
**480 MB/S**  
Trasferimento dati  
Data transfer

**1500 mA**  
Trasferimento corrente  
Power transfer



**APPLE 2 IN 1, CAVO RICARICA E SINCRONIZZAZIONE CON ADATTATORE PER AURICOLARE**

Adattatore per utilizzare auricolari lightning (MFI) e ricaricare il dispositivo contemporaneamente. Compatibile con ricarica veloce.  
Struttura in metallo, collo rinforzato

**APPLE 2 IN 1, CHARGE & SYNC CABLE WITH ADAPTER FOR EARPHONES**

Adapter for connecting lightning earphones (MFI) and recharge the device simultaneously. Compatible with fast charge.  
Metal frame, reinforced neck

**38849** 100 cm

**38850** 200 cm

Scatola / Box 10 / 120



Apple 8 PIN



**SPLITTER, ADATTATORE PER COLLEGARE CAVO RICARICA E AURICOLARI**

Permette di ricaricare il telefono, effettuare chiamate, ascoltare la musica ed utilizzare i comandi degli auricolari (MFI) contemporaneamente. Compatibile con ricarica veloce. Struttura in metallo

**SPLITTER, ADAPTER FOR CONNECTING RECHARGE CABLE AND EARPHONES**

Allows to recharge, make phone calls, listen to music and use remote control of the earphones (MFI) simultaneously. Compatible with fast charge.  
Metal frame

**38859**

Scatola / Box 10 / 120



- Ricarica**  
Recharge
- Chiamate**  
Calls
- Musica**  
Music
- Auricolari**  
Earphones
- Funziona con iTunes**  
Works with iTunes

**Apple LIGHTNING**

Made for  
iPod iPhone iPad



**Fino a: / Up to:**  
**480 MB/S**  
Trasferimento dati  
Data transfer

**3000 mA**  
Trasferimento corrente  
Power transfer



**CAVO RICARICA E SINCRONIZZAZIONE**

Presia facilitata mentre giochi, guardi video o usi il GPS in posizione orizzontale, senza nessun intralcio. Connettore originale Apple. Compatibile con ricarica veloce. Struttura in metallo, collo rinforzato

**CHARGE & SYNC CABLE**

Easier handling of the phone while watching videos, playing games, GPS horizontal mode...no obstruction. Original Apple connector. Compatible with fast charge. Metal frame, reinforced neck

<b>38836</b>	<b>100 cm</b>
<b>38837</b>	<b>200 cm</b>

Scatola / Box  10 / 120

**▶ PLAY GAMING VIDEO GPS**



**USB TYPE C**

**Ultra Speed**



**Fino a: / Up to:**  
**480 MB/S**  
Trasferimento dati  
Data transfer

**3000 mA**  
Trasferimento corrente  
Power transfer



**CAVO RICARICA E SINCRONIZZAZIONE**

Presia facilitata mentre giochi, guardi video o usi il GPS in posizione orizzontale, senza nessun intralcio. Compatibile con ricarica super veloce. Struttura in metallo, collo rinforzato

**CHARGE & SYNC CABLE**

Easier handling of the phone while watching videos, playing games, GPS horizontal mode...no obstruction. Compatible with super fast charge. Metal frame, reinforced neck

<b>38838</b>	<b>100 cm</b>
<b>38839</b>	<b>200 cm</b>

Scatola / Box  10 / 120

**▶ PLAY GAMING VIDEO GPS**



**MICRO USB**



**Fino a: / Up to:**  
**480 MB/S**  
Trasferimento dati  
Data transfer

**3000 mA**  
Trasferimento corrente  
Power transfer



**CAVO RICARICA E SINCRONIZZAZIONE**

Presia facilitata mentre giochi, guardi video o usi il GPS in posizione orizzontale, senza nessun intralcio. Compatibile con ricarica veloce. Struttura in metallo, collo rinforzato

**CHARGE & SYNC CABLE**

Easier handling of the phone while watching videos, playing games, GPS horizontal mode...no obstruction. Compatible with fast charge. Metal frame, reinforced neck

<b>38834</b>	<b>100 cm</b>
<b>38835</b>	<b>200 cm</b>

Scatola / Box  10 / 120

**▶ PLAY GAMING VIDEO GPS**



MICRO USB

SUPER RESISTANT

Fino a: / Up to:  
**480 MB/S**  
Trasferimento dati  
Data transfer

**3000 mA**  
Trasferimento corrente  
Power transfer



**CAVO RICARICA E SINCRONIZZAZIONE**  
Compatibile con ricarica veloce.  
Struttura in metallo, collo rinforzato,  
antistrappo.

**CHARGE & SYNC CABLE**  
Compatible with fast charge.  
Metal frame, reinforced neck, tear proof

**38885** 100 cm

Scatola / Box 10 / 120



MICRO USB

SUPER RESISTANT

Fino a: / Up to:  
**480 MB/S**  
Trasferimento dati  
Data transfer

**3000 mA**  
Trasferimento corrente  
Power transfer



**CAVO RICARICA E SINCRONIZZAZIONE**  
Compatibile con ricarica veloce.  
Struttura in metallo, collo rinforzato,  
antistrappo.

**CHARGE & SYNC CABLE**  
Compatible with fast charge.  
Metal frame, reinforced neck, tear proof

**38886** 100 cm

Scatola / Box 10 / 120



MICRO USB

Fino a: / Up to:  
**480 MB/S**  
Trasferimento dati  
Data transfer

**3000 mA**  
Trasferimento corrente  
Power transfer



**CAVO RICARICA E SINCRONIZZAZIONE**  
Compatibile con ricarica veloce.  
Collo rinforzato

**CHARGE & SYNC CABLE**  
Compatible with fast charge.  
Reinforced neck

**38884** 100 cm

Scatola / Box 10 / 120



**MICRO USB**

Fino a: / Up to:

**480 MB/S**

Trasferimento dati  
Data transfer

**3000 mA**

Trasferimento corrente  
Power transfer



**CAVO RICARICA E SINCRONIZZAZIONE**

Compatibile con ricarica veloce.  
Collo rinforzato

**CHARGE & SYNC CABLE**

Compatible with fast charge.  
Reinforced neck

**38931** 100 cm

**38921** 200 cm

Scatola / Box  10 / 120



**USB TYPE C**

**Ultra Speed**

Fino a: / Up to:

**480 MB/S**

Trasferimento dati  
Data transfer

**3000 mA / 18w**

Trasferimento corrente  
Power transfer



**CAVO RICARICA E SINCRONIZZAZIONE**

Compatibile con ricarica super veloce.  
Struttura in metallo, collo rinforzato.

**CHARGE & SYNC CABLE**

Compatible with super fast charge.  
Metal frame, reinforced neck.

**38890** 100 cm

**38891** 200 cm

Scatola / Box  10 / 120





**Apple LIGHTNING**

Made for

**Fino a: / Up to:**  
**480 MB/S**  
*Trasferimento dati*  
*Data transfer*

**3000 mA**  
*Trasferimento corrente*  
*Power transfer*



**CAVO RICARICA E SINCRONIZZAZIONE**  
 Compatibile con ricarica veloce.  
 Connettore originale Apple.  
 Collo rinforzato

**CHARGE & SYNC CABLE**  
 Compatible with fast charge.  
 Original Apple connector.  
 Reinforced neck

<b>38930</b>	<b>100 cm</b>
<b>38920</b>	<b>200 cm</b>

Scatola / Box 10 / 120



**Apple LIGHTNING**

Made for

**Fino a: / Up to:**  
**480 MB/S**  
*Trasferimento dati*  
*Data transfer*

**3000 mA**  
*Trasferimento corrente*  
*Power transfer*



**CAVO RICARICA E SINCRONIZZAZIONE**  
 Compatibile con ricarica veloce.  
 Connettore originale Apple.  
 Collo rinforzato

**CHARGE & SYNC CABLE**  
 Compatible with fast charge.  
 Original Apple connector.  
 Reinforced neck

<b>38887</b>	<b>100 cm</b>
--------------	---------------

Scatola / Box 10 / 120



**Apple DOCK 30 PIN**

**Fino a: / Up to:**  
**480 MB/S**  
*Trasferimento dati*  
*Data transfer*

**3000 mA**  
*Trasferimento corrente*  
*Power transfer*



**CAVO RICARICA E SINCRONIZZAZIONE**  
 Compatibile con ricarica veloce

**CHARGE & SYNC CABLE**  
 Compatible with fast charge

<b>38932</b>	<b>100 cm</b>
--------------	---------------

Scatola / Box 10 / 120



Apple LIGHTNING + MICRO USB



100 cm

OK SYNC

2 in 1

**CAVO RICARICA E SINCRONIZZAZIONE**

Compatibile con ricarica veloce.

Connettore originale Apple.

**CHARGE & SYNC CABLE**

Compatible with fast charge.

Original Apple connector.

**38935 100 cm**

Scatola / Box 10 / 100

Made for  
iPod iPhone iPad

Fino a / Up to:

**480 MB/S**

Trasferimento dati

Data transfer

**3000 mA**

Trasferimento corrente

Power transfer



USB 3 MICRO B



100 cm

OK SYNC

**CAVO RICARICA E SINCRONIZZAZIONE**

**CHARGE & SYNC CABLE**

**38934 100 cm**

Scatola / Box 10 / 100



Samsung DOCK 30 PIN



100 cm

OK SYNC

**CAVO RICARICA E SINCRONIZZAZIONE**

**CHARGE & SYNC CABLE**

**38933 100 cm**

Scatola / Box 10 / 100



**UNIVERSAL CONNECTOR**

**SUPER RESISTANT**

Fino a: / Up to:  
**480 MB/S**  
Trasferimento dati  
Data transfer

**3000 mA / 18w**  
Trasferimento corrente  
Power transfer



**CAVO RICARICA E SINCRONIZZAZIONE**  
Compatibile con ricarica veloce.  
Struttura in metallo, collo rinforzato.

**CHARGE & SYNC CABLE**  
Compatible with fast charge.  
Metal frame, reinforced neck.

**38840** 100 cm  
**38841** 200 cm

Scatola / Box 10 / 120

**UNIVERSAL CONNECTOR**

Apple  
8 Pin



**ULTIMATE CABLE**

**1** Cavo Cable **6** Combinazioni possibili Possible Combinations

**USB TYPE C** + **USB 3.0** + **UNIVERSAL CONNECTOR**



**6 in 1**



**CAVO RICARICA E SINCRONIZZAZIONE**  
Compatibile con ricarica super veloce.  
Struttura in metallo, collo rinforzato.

**CHARGE & SYNC CABLE**  
Compatible with super fast charge.  
Metal frame, reinforced neck.

**38846** 100 cm

Scatola / Box 10 / 120

Fino a: / Up to:  
**480 MB/S**  
Trasferimento dati  
Data transfer

**3000 mA / 18w**  
Trasferimento corrente  
Power transfer

Dati + ricarica  
Data + charge

**OTG**  
On The Go

**UNIVERSAL CONNECTOR**

Apple  
8 Pin

USB 3.0

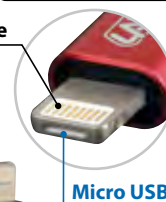

Type C

Type C

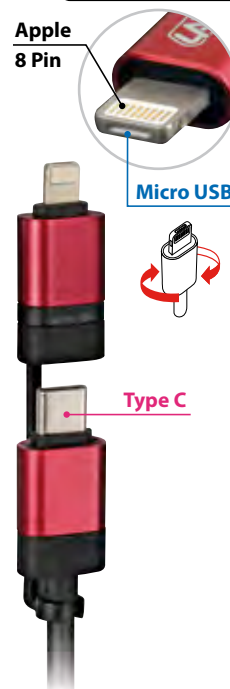

Apple 8 PIN + MICRO USB + USB TYPE C



3 in 1

100 cm

**CERBERO, CAVO RICARICA CON 3 CONNETTORI**  
 Ricarica fino a 3 dispositivi contemporaneamente usando un unico cavo. 3A massimi condivisi. Compatibile con ricarica veloce.

**CERBERO, CHARGE CABLE WITH 3 CONNECTORS**  
 Recharge up to 3 devices simultaneously using only 1 cable. Compatible with fast charge. 3 A max shared

**38847 100 cm**

Scatola / Box 10 / 120



Fino a / Up to:

**480 MB/S**  
 Trasferimento dati  
 Data transfer

**3000 mA**  
 Trasferimento corrente  
 Power transfer



USB TYPE-C

**CAVO OTG USB > USB TYPE-C**  
 Per collegare periferiche Usb esterne (memorie, tastiere, fotocamere...) a smartphone o tablet che dispongono della funzione USB OTG

**USB > USB TYPE-C OTG CABLE**  
 For connecting peripheral Usb devices (flash drives, keyboards, cameras...) to smartphones or tablets which support USB OTG function

**38858 20 cm**

Blister 10 / 120

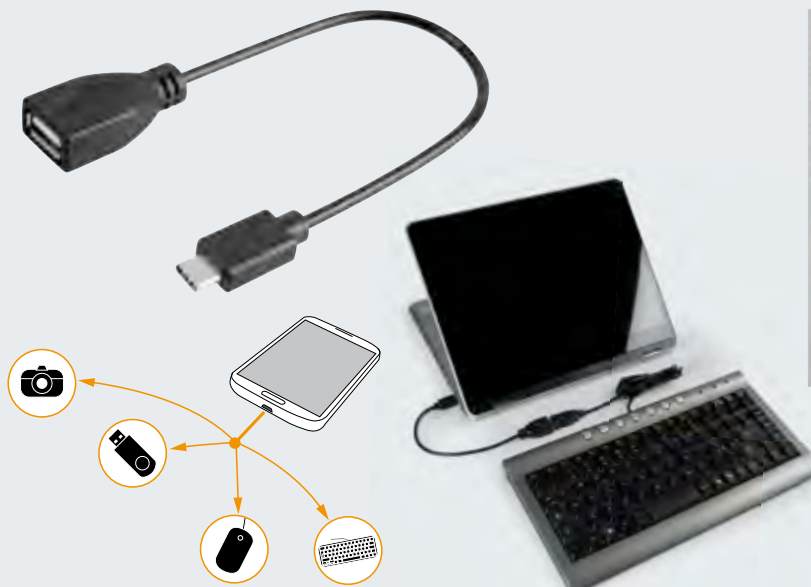

20 cm

**MICRO USB**

**CAVO OTG USB > MICRO USB**

Per collegare periferiche Usb esterne (memorie, tastiere, fotocamere...) a smartphone o tablet che dispongono della funzione USB OTG

**USB > MICRO USB OTG CABLE**

For connecting peripheral Usb devices (flash drives, keyboards, cameras...) to smartphones or tablets which support USB OTG function

**38929** 20 cm

Scatola / Box 10 / 120

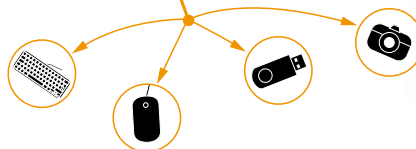

**MICRO USB**

**CAVO OTG**

**MICRO USB > MICRO USB**

Per trasferire corrente e dati da uno smartphone/tablet ad un altro.

Nota: trasferimento dati solo Android 4.0 e superiore

**MICRO USB > MICRO USB OTG CABLE**

For transferring current and data from a smartphone/tablet to another one.

Note: data transfer available only on Android 4.0 and above

**38936** 30 cm

Scatola / Box 10 / 100



Display 10 pz

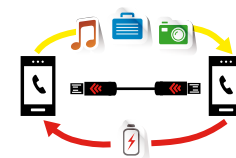

**AUX - AUX**

**PHIXIA, CAVO AUX-AUX**

Cavo AUX piatto antigroviglio con jack stereo da 3,5 mm.

**PHIXIA, AUX-AUX CABLE**  
Anti-tangle flat AUX cable with 3,5 mm stereo jack.

**38900** 120 cm

Scatola / Box 10 / 120



Colori Assortiti  
Assorted Colours

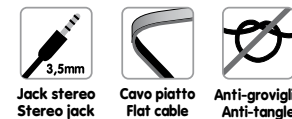

**AUX - AUX**

**PHIXIA-90°, CAVO AUX-AUX**

Cavo AUX piatto antigroviglio con jack stereo da 3,5 mm.

**PHIXIA-90°, AUX-AUX CABLE**  
Anti-tangle flat AUX cable with 3,5 mm stereo jack.

**38899** 120 cm

Scatola / Box 10 / 120

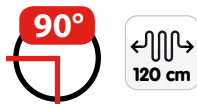

Colori Assortiti  
Assorted Colours

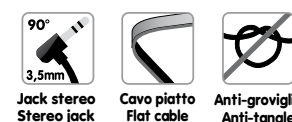

**PORTACHIAVE CON CAVO RICARICA E SINCRONIZZAZIONE**

Piccolo e portatile, ideale per l'utilizzo con i power bank. Adatto per ricarica veloce

**KEY CHAIN WITH CHARGE & SYNC CABLE**  
Small and portable, perfect to use with your power bank. Suitable for fast charge.

<b>38889</b>	1 pz	Blisters	10 / 120
<b>38889D</b>	Display 10 pz	Scatola / Box	1



Display 10 pcs

**PORTACHIAVE CON CAVO RICARICA E SINCRONIZZAZIONE**

Piccolo e portatile, ideale per l'utilizzo con i power bank. Adatto per ricarica veloce. Connettore originale Apple.

**KEY CHAIN WITH CHARGE & SYNC CABLE**  
Small and portable, perfect to use with your power bank. Suitable for fast charge. Original Apple connector.

<b>38919</b>	1 pz	Blisters	10 / 120
<b>38919D</b>	Display 10 pz	Scatola / Box	1

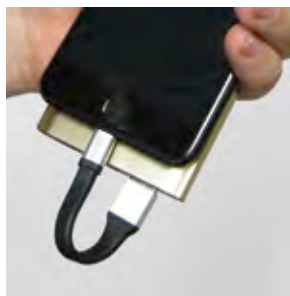

**Apple LIGHTNING**  
Made for iPod iPhone iPad



Display 10 pcs

**PORTACHIAVE CON CAVO RICARICA E SINCRONIZZAZIONE**

Piccolo e portatile, ideale per l'utilizzo con i power bank. Adatto per ricarica veloce

**KEY CHAIN WITH CHARGE & SYNC CABLE**  
Small and portable, perfect to use with your power bank. Suitable for fast charge.

<b>38918</b>	1 pz	Blisters	10 / 120
<b>38918D</b>	Display 10 pz	Scatola / Box	1



Display 10 pcs

**SET 3 CLIPS FERMACAVI ADESIVE**  
Organizza e tieni in ordine i tuoi cavi.  
Base adesiva adatta al fissaggio su  
superfici lisce. Struttura in morbido  
silicone. Alloggia cavi fino a Ø 4 mm

**ADHESIVE CABLE CLIPS, 3 PCS SET**  
Organizer your cable. Adhesive base  
that can be fixed onto any smooth  
surface. Soft silicone structure.  
Compatible with cable up to Ø 4 mm

**38854**

Blister 10 / 120

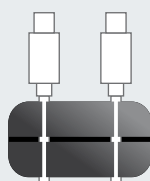

**Doppio  
Double**

**3 pcs  
SET**



**Singolo  
Single**



**Silicone flessibile  
Flexible silicone**



**2 CAVI  
2 CABLES**



**CABLE-FIX,  
CLIPS FERMACAVI ADESIVE**

Per fermare i cavetti di auricolari, caricatori  
cellulari, alimentatori usb, navigatori  
satellitari, cuffie...

**CABLE-FIX, ADHESIVE CABLE CLIPS**

To hold, organise, and keep firm in position  
small cables of phone chargers, usb cables,  
gps navigator, earphones.

**70036** 6 pz D/Blister 10 / 100

**70037** 50 pz Busta / Bag 5 / 50



**CABLE-CLAMP,  
CLIPS FERMACAVI ADESIVE**

Per fermare i cavetti di auricolari,  
caricatori cellulari, alimentatori usb,  
navigatori satellitari, cuffie...

**CABLE-CLAMP, ADHESIVE CABLE CLIPS**

To hold, organise, and keep firm in  
position small cables of phone chargers,  
usb cables, gps navigator, earphones.

**70034** 6 pz

D/Blister 10 / 100



## 4 Technologies



HUAWEI FCP

MTK PE 2.0

BC 1.2 universal fast charge protocol

Compatibili con: / Compatibles with:

**Apple, Htc, Huawei, Lg, Samsung, Sony, Xiaomi...**

Uscita USB 1  
USB 1 output

Ingresso Type C  
Type C input

Ingresso Micro USB  
Micro USB input



Uscita USB  
Ricarica adattiva universale  
**USB output**  
Universal adaptive charge

1 TYPE C  
1 MICRO USB  
2 USB

**ULTRA FAST CHARGE**  
Ricarica ULTRA-RAPIDA

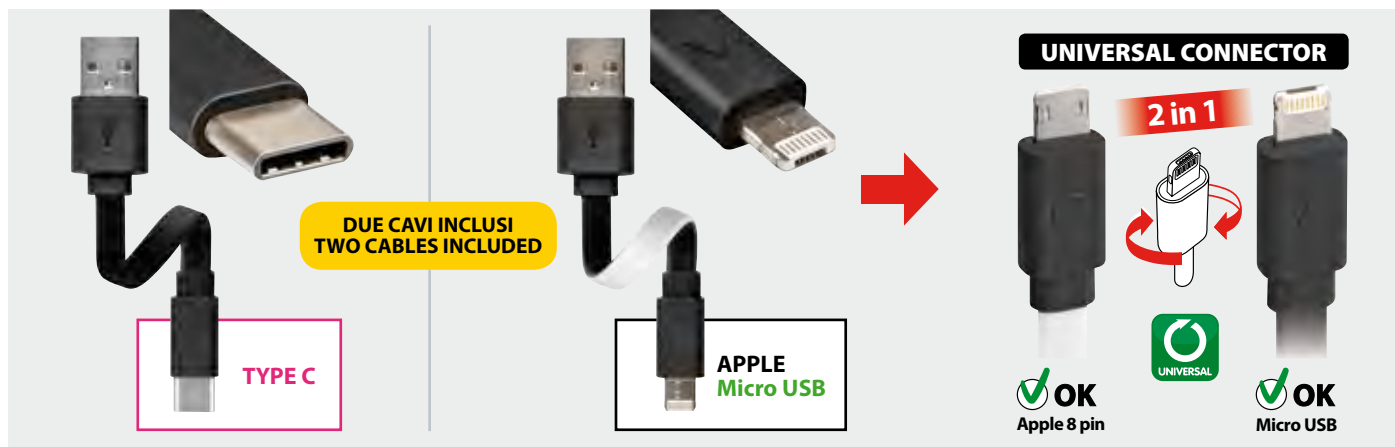

### HYPER TANK 8000, CARICABATTERIE USB PORTATILE INTELLIGENTE

- Capacità batteria: 8000mAh batteria ai polimeri di litio.
- Ingresso DC 5V 2A - Micro USB e Type C.
- Uscita USB 1: 5V 1A. Uscita USB 2: 3,75V-6V, 3A / 9V, 2A / 12V, 1,5 A (18 W ricarica adattiva).
- Ultra Fast Charge: QC 3.0 / Huawei FCP/ MTK PE 2.0 / BC 1.2 protocollo di ricarica rapida universale. Ricarica veloce per Apple, Samsung, Huawei... e tutti gli altri smartphone.
- Fast Recharge: il power bank si ricarica più velocemente.
- Speciale cavo con connettore 2 in 1 adatto per ricaricare dispositivi Apple 8 pin / Micro USB incluso (adatto anche per ricaricare il power bank). Cavo Type C incluso.
- Protezione da: corto circuito, surriscaldamento, sovratensione e sovraccarico

### HYPER TANK 8000, PORTABLE SMART BATTERY CHARGER

- Battery capacity: 8000mAh lithium polymer battery.
- Input DC 5V 2A - Micro USB and Type C.
- Output USB 1: 5V 1A. Output USB 2: 3,75V-6V, 3A / 9V, 2A / 12V, 1,5 A (18 W adaptive recharge).
- Ultra Fast Charge: QC 3.0 / Huawei FCP/ MTK PE 2.0 / BC 1.2 universal fast charge protocol. - Fast charge for Apple, Samsung, Huawei... and any other smartphone.
- Fast Recharge: the power bank recharges faster.
- Special cable with 2 in 1 connector compatible for charging Apple 8 pin / Micro USB devices included (suitable for charging also the power bank). Type C cable included.
- Overload, overvoltage, overtemperature and short circuit protection



**38824**

Scatola / Box 10 / 40



**TANK 10000, CARICABATTERIE USB PORTATILE INTELLIGENTE**

- Capacità batteria: 10000 mAh batteria ai polimeri di litio.
- Ingresso DC 5V 2A - Micro USB e Type C.
- Uscita 5V 2A condiviso tramite 2 porte USB.
- Fast Charge: lo speciale chip intelligente riconosce il dispositivo collegato e fornisce energia ottimale per una ricarica veloce e protetta.
- Fast Recharge: il power bank si ricarica più velocemente.
- Speciale cavo con connettore 2 in 1 adatto per ricaricare dispositivi Apple 8 pin / Micro USB incluso (adatto anche per ricaricare il power bank).
- Protezione da: corto circuito, surriscaldamento, sovratensione e sovraccarico

**TANK 10000, SMART PORTABLE USB BATTERY CHARGER**

- Battery capacity: 10000mAh - lithium polymer battery.
- Input DC 5V 2A - Micro USB and Type C
- Output 5V 2A shared via 2 USB.
- Fast Charge: the special smart chip recognizes the connected device and supplies the correct energy for a fast and safe recharge
- Fast Recharge: the power bank recharges faster
- Special cable with 2 in 1 connector compatible for charging Apple 8 pin / Micro USB devices included (suitable for charging also the power bank).
- Overload, overvoltage, overtemperature and short circuit protection.

**38823**

Scatola / Box 10 / 40

Uscita USB 1  
Ricarica veloce  
USB 1 output  
Fast charge

Ingresso Type C  
Type C input

Ingresso Micro USB  
Micro USB input

Uscita USB 2  
Ricarica veloce  
USB 2 output  
Fast charge

1 TYPE C  
1 MICRO USB  
2 USB



**FAST CHARGE**  
Ricarica VELOCE



Incluso cavo  
MICRO USB +  
APPLE 8 PIN  
Cable included

**UNIVERSAL CONNECTOR**

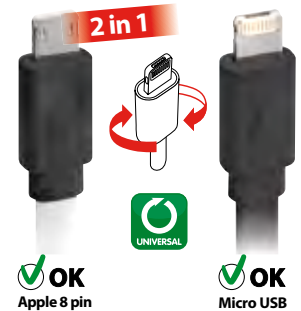

**TANK 7500, CARICABATTERIE USB PORTATILE INTELLIGENTE**

- Capacità batteria: 7500 mAh.
- Ingresso DC 5V 2A - Micro USB e Type C.
- Uscita 5V 2A condiviso tramite 2 porte USB.
- Fast Charge: lo speciale chip intelligente riconosce il dispositivo collegato e fornisce energia ottimale per una ricarica veloce e protetta.
- Fast Recharge: il power bank si ricarica più velocemente.
- Speciale cavo con connettore 2 in 1 adatto per ricaricare dispositivi Apple 8 pin / Micro USB incluso (adatto anche per ricaricare il power bank).
- Protezione da: corto circuito, surriscaldamento, sovratensione e sovraccarico

**TANK 7500, SMART PORTABLE USB BATTERY CHARGER**

- Battery capacity: 7500 mAh.
- Input DC 5V 2A - Micro USB and Type C.
- Output 5V 2A shared via 2 USB.
- Fast Charge: the special smart chip recognizes the connected device and supplies the correct energy for a fast and safe recharge.
- Fast Recharge: the power bank recharges faster.
- Special cable with 2 in 1 connector compatible for charging Apple 8 pin / Micro USB devices included (suitable for charging also the power bank).
- Overload, overvoltage, overtemperature and short circuit protection.

**38822**

Scatola / Box 10 / 40

Uscita USB 1  
Ricarica veloce  
USB 1 output  
Fast charge

Ingresso Type C  
Type C input

Uscita USB 2  
Ricarica veloce  
USB 2 output  
Fast charge

Ingresso Micro USB  
Micro USB input

1 TYPE C  
1 MICRO USB  
2 USB



**FAST CHARGE**  
Ricarica VELOCE



Incluso cavo  
MICRO USB +  
APPLE 8 PIN  
Cable included

**UNIVERSAL CONNECTOR**



**TANK 5000, CARICABATTERIE USB PORTATILE**

- Capacità batteria: 5000 mAh.
- Ingresso DC 5V 1A - Micro USB / Uscita DC 5V 1A - USB.
- Speciale cavo con connettore 2in1 adatto per ricaricare dispositivi Apple 8 pin / Micro USB incluso (adatto anche per ricaricare il power bank).
- Protezione da: corto circuito, surriscaldamento, sovratensione e sovraccarico

**TANK 5000, PORTABLE USB BATTERY CHARGER**

- Battery capacity: 5000 mAh.
- Input DC 5V 1A - Micro USB / Output DC 5V 1A - USB.
- Special cable with 2 in 1 connector compatible for charging Apple 8 pin / Micro USB devices included (suitable for charging also the power bank).
- Overload, overvoltage, overtemperature and short circuit protection.

**38821**

Scatola / Box 10 / 60



5000 mAh    OUT 1000 mA    ON-OFF             10 cm



Ingresso Micro USB  
Micro USB input

Uscita USB  
USB output

1 MICRO USB  
1 USB

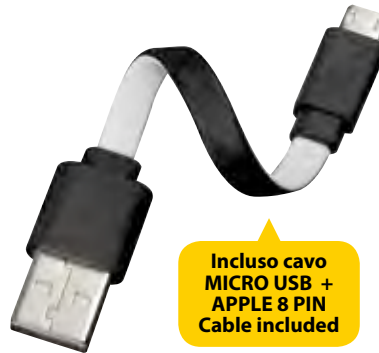

Incluso cavo  
MICRO USB +  
APPLE 8 PIN  
Cable included

**UNIVERSAL CONNECTOR**



**UNI-POWER 2600 POWER PACK  
CON CAVO UNIVERSAL APPLE / MICRO USB**

Batteria d'emergenza con presa USB.  
Cavo di ricarica e sincronizzazione dati da 10cm universale per Apple 8 pin e Micro Usb.  
Per dispositivi Apple (Ipod, Iphone - 8pin) è sufficiente inserire il connettore con il lato bianco verso l'alto mentre per dispositivi Android (Samsung, Huawei... - Micro Usb) inserire con il lato nero verso l'alto. Indicatore del livello di carica della batteria e pratica torcia a led.

Fornita carica e pronta all'uso

**UNI-POWER 2600 POWER PACK  
WITH APPLE / MICRO USB UNIVERSAL CABLE**

Compact portable charger.  
10 cm charge and sync universal cable for Apple 8 pin and Android Micro Usb. For Apple devices (Iphone, Ipod - 8 pin) insert the cable with the white side facing up. For Android devices (Samsung, Huawei... Micro Usb) insert the cable with the black side facing up. Battery charge indicator and light. Supplied already charged

**38820**

Scatola / Box 10 / 120

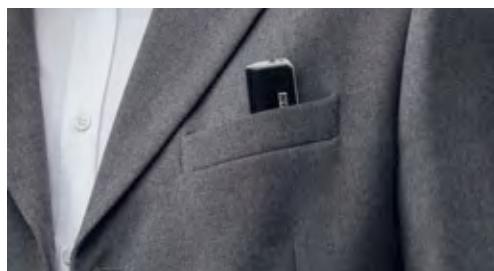

2600 mAh    OUT 1000 mA    ON-OFF             10 cm



TORCIA A LED  
LED TORCH

1 USB



Incluso cavo  
MICRO USB +  
APPLE 8 PIN  
Cable included

**UNIVERSAL CONNECTOR**



**POWER-PACK 4000 FAST CHARGE, CARICABATTERIE USB PORTATILE**  
 Sottile batteria d'emergenza ai polimeri di litio con 2 porte Usb. Leggera struttura in alluminio che facilita la dispersione di calore. Fornita carica e pronta all'uso.

**POWER-PACK 4000 FAST CHARGE, PORTABLE USB BATTERY CHARGER**  
 Emergency power bank with Usb. Slim lithium polymer battery. Light aluminium structure that helps dissipating the heat. Supplied already charged.

- 38914** Oro Gold
- 38915** Oro Rosa Pink Gold

Scatola / Box 10 / 100



1 MICRO USB  
2 USB

**FAST CHARGE**  
 Ricarica VELOCE

4000 mAh    OUT 2400 mA    2X PIU VELOCE FASTER    ON-OFF    30 cm



**POWER-PACK 4000**  
 Batteria d'emergenza con presa USB. Fornita carica e pronta all'uso. Con pratica torcia e indicatore di batteria a Led.

**POWER-PACK 4000**  
 Emergency power bank with USB port. Supplied already charged. With torch and Led battery indicator.

- 38911**

Scatola / Box 10 / 60



TORCIA A LED  
LED TORCH

ALLUMINIO  
ALUMINIUM



1 MICRO USB  
1 USB

4000 mAh    OUT 1000 mA    ON-OFF    30 cm

Colori Assortiti  
Argento / Oro  
Assorted Colours  
Silver / Gold

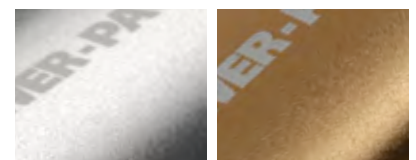

**ESPOSITORE 10 PZ ASSORTITI, POCKET-POWER 2200**  
 Caricabatteria portatile. Forniti carichi e pronti all'uso.

**DISPLAY 10 PCS ASSORTED, POCKET-POWER 2200**  
 Emergency power banks. Supplied already charged.

- 38910** Display 10 pcs

Display 1 / 10



Colori Assortiti  
Bianco / Nero  
Assorted Colours  
Black / White



2200 mAh    OUT 1000 mA    1 USB



**12 connettori  
12 plugs**

**12V** **LED**

Acer - Asus - Compaq - Dell  
Fujitsu - Gateway - Hasee  
Hp - Ibm - Lenovo - Mini  
Nec - Samsung - Sony  
Siemens - Tci - Haier - Toshiba

IN	12 V	Standard
OUT	15/16/18,5/19/19,5/20 V	90 W
Cavo	140 cm	

**NOTEX, ALIMENTATORE UNIVERSALE PER NOTEBOOK - 12V**  
12 connettori specifici per ricaricare tutti i computer portatili delle maggiori marche. 90W max con regolatore automatico della tensione di uscita in base al connettore utilizzato. Cavo alimentazione da 140 cm. Protezione da cortocircuito, sovratensione, sovravoltaggio e surriscaldamento.

**NOTEX, UNIVERSAL NOTEBOOK CHARGER - 12V**  
Specific for charging your notebook with any 12V cigarette lighter socket. 90W max with automatic voltage management based on the used connector. Short circuit, over current, over voltage and over temperature protection.

**74532**

D/Blister 10 / 40

**170 cm**

**2,1 x 5,5 mm**

**5 A max** **12-24V** **Fuse**

IN	12/24 V	Standard
OUT	12/24 V	Jack 2,1x5,5 mm
Cavo	170 cm	5 A

**SPINOTTO PER PRESA ACCENDISIGARI CON CONNETTORE JACK, 12/24V**  
Consente di alimentare televisioni, amplificatori, navigatori, ecc... tramite la presa accendisigari del proprio veicolo.

**CIGARETTE LIGHTER PLUG WITH JACK CONNECTOR, 12/24V**  
Enables the power old electronic appliances through the cigarette lighter socket of your vehicle.

**38978**

D/Blister 10 / 100

**TRASFORMATORE 220V > 12V**  
Con presa tipo accendisigari  
**220V > 12V ADAPTOR**  
With cigarette lighter socket

**70128**

D/Blister 6 / 36

**230V**

IN	230 V	
OUT	12 V	Standard 0,9 A max
Cavo	180 cm	

**TRASFORMATORE 12/24V - 2000 MA**  
Con circuito switching stabilizzato e 6 spinotti adattatori. Per alimentare apparecchi a batteria tramite la presa accendisigari 12 o 24V

**REGULATED DC/DC CONVERTER, 12/24V - 2000 MA**  
With switching circuit and 6 connectors. For use battery devices with cigarette lighter (12 or 24V)

**98145**

D/Blister 5 / 50

**12-24V**

IN	12 / 24V	Standard
OUT	1,5 / 3 / 4,5 / 6 / 9 / 12V	2 A

**TRASFORMATORE 220-240V > 12V**  
Permette di utilizzare, a casa o al campeggio, tutti gli apparecchi 12V comunemente collegati alla presa accendisigari in auto: frigoriferi, ventilatori, caricabatteria telefoni cellulari, lampade, torce...

**220-240V > 12V CONVERTER**  
For connecting any 12V DC appliances (cool boxes, fans, lamps...) to the AC 220-240V power outlets. Suitable for home, camping...

**70145**

Scatola / Box 10 / 50

**230V**

IN	230 V	
OUT	12 V	Standard 5,8 A max
Cavo	350 cm	

**230V**

# POWER INVERTER

## Pure Sine wave



**POWER INVERTER, PURE SINE WAVE, TRASFORMATORI DI CORRENTE A ONDA SINUSOIDALE PURA**  
L'inverter ad onda sinusoidale pura eroga in uscita una tensione di 230V con una forma d'onda uguale a quella della rete elettrica domestica. Garantendo una forma d'onda della corrente in uscita a 230V come quella della normale rete elettrica di casa, è molto più sicura e pulita con immediati vantaggi:

- **Compatibilità con tutti gli apparecchi, anche quelli che hanno difficoltà a funzionare con inverter ad onda sinusoidale modificata.**
- **Minori consumi e maggiore efficienza energetica.**
- **Maggior potenza effettiva erogata.**
- **Maggior sicurezza contro corto-circuiti e surriscaldamento**
- Protezioni di sicurezza incorporate per proteggere il trasformatore, l'apparecchiatura ad esso collegata e la batteria del veicolo.
- Cavi batteria e spinotto accendisigari inclusi.
- Vano portafusibili esterno e coppia di fusibili aggiuntivi in dotazione

**PURE SINE WAVE POWER INVERTERS**  
Pure sine wave power inverter provides a voltage of 230V with a waveform equal to the domestic electricity. Guarantees a waveform of the output current at 230V as the normal power grid, so it is much safer and cleaner with immediate benefits:

- **Compatibility with all kind of devices, even those who have difficulty working with modified sine wave inverter.**
- **Reduced fuel consumption and more energy efficiency.**
- **More actual power supplied.**
- **Greater safety against short-circuits and over-heating**
- Over-voltage, overload, short-circuit and over-temperature protection and lack voltage shut off.
- Battery clamps and cigarette lighter plug included.
- External fuse compartment and pair of additional fuses included

**POWER INVERTER, PURE SINE WAVE, 300**  
Potenza massima **300W** Max power  
Spunto massimo **600W** Peak power  
**74516** 125x65x225 mm  
Scatola / Box 4 / 8

Con presa **USB 2.0**  
With USB 2.0 socket

Max continuous power  
**300 W**  
continui

Peak power  
**600 W**  
di spunto

**Vano portafusibili esterno**  
External fuse compartment

Max continuous power  
**600 W**  
continui

Peak power  
**1200 W**  
di spunto

**Vano portafusibili esterno**  
External fuse compartment

Max continuous power  
**600 W**  
continui

Peak power  
**1200 W**  
di spunto

**POWER INVERTER, PURE SINE WAVE, 600**  
Potenza massima **600W** Max power  
Spunto massimo **1200W** Peak power  
**74517** 125x65x310 mm  
Scatola / Box 4 / 8

# POWER INVERTER

## MODIFIED SINE WAVE

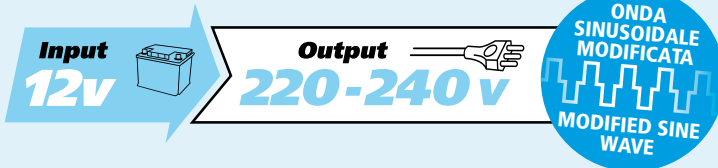

Trasformatori di corrente da 12V (corrente continua) a 220V (corrente alternata). Permettono di collegare apparecchiature alimentate a 220V a qualsiasi fonte di energia da 12V: autovetture, furgoni o imbarcazioni. **Protezione contro i corto circuiti e sovraccarichi**

Power inverters from 12V DC to 220V AC. These special units allow 220V appliances to be connected to 12V power sources, such as cars, vans or boats. **High-low voltage and short circuit protection. Overload and thermal protection**

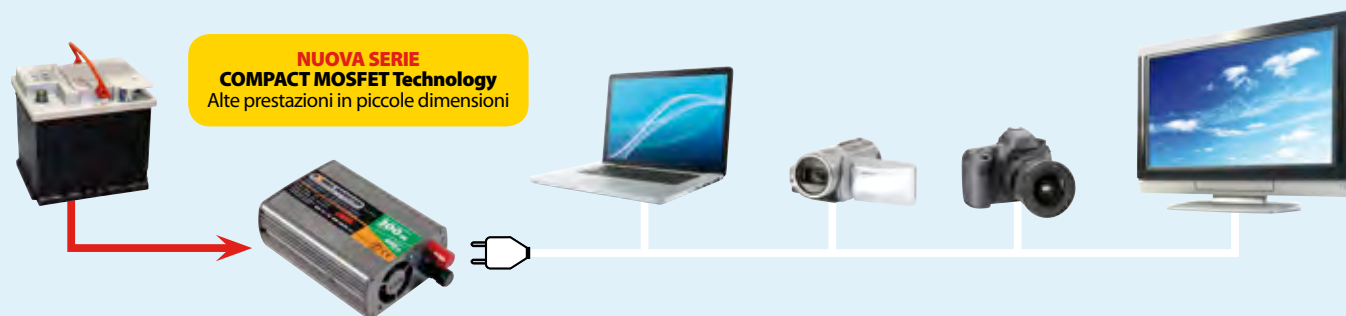

**NUOVA SERIE**  
**COMPACT MOSFET Technology**  
Alte prestazioni in piccole dimensioni

Potenza max **60 W** Max power  
Spunto max **100 W** Peak power



(E) R10

**POWER INVERTER 60**  
Potenza massima **60W** Max power  
Spunto massimo **100W** Peak power

**74510**

D/Blister  4 / 20



Potenza max **200 W** Max power  
Spunto max **400 W** Peak power



(E) R10

**POWER INVERTER 200**  
Potenza massima **200W** Max power  
Spunto massimo **400W** Peak power

**74520**

D/Blister  5 / 20

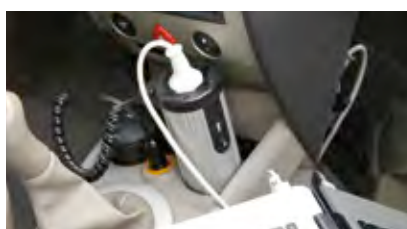

Potenza max **175 W**  
Max power

Spunto max **350 W**  
Peak power



(E) R10

**POWER INVERTER 175**  
Potenza massima **175W** Max power  
Spunto massimo **350W** Peak power

**74521**

D/Blister 5 / 20



Potenza max **150 W**  
Max power

Spunto max **300 W**  
Peak power



(E) R10

FUSIBILI ESTERNI  
EXTERNAL FUSES

**POWER INVERTER 150**  
Potenza massima **150W** Max power  
Spunto massimo **300W** Peak power

**74511**

Scatola / Box 4 / 12



Potenza max **300 W**  
Max power

Spunto max **600 W**  
Peak power



(E) R10

FUSIBILI ESTERNI  
EXTERNAL FUSES

**POWER INVERTER 300**  
Potenza massima **300W** Max power  
Spunto massimo **600W** Peak power

**74512**

Scatola / Box 4 / 12

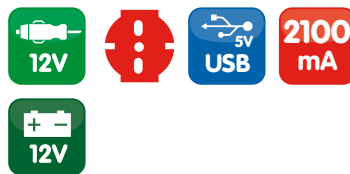

Potenza max **600 W**  
Max power

Spunto max **1200 W**  
Peak power



(E) R10

FUSIBILI ESTERNI  
EXTERNAL FUSES

**POWER INVERTER 600**  
Potenza massima **600W** Max power  
Spunto massimo **1200W** Peak power

**74513**

Scatola / Box 4 / 12



Potenza max **1000 W**  
Max power

Spunto max **2000 W**  
Peak power



(E) R10

FUSIBILI ESTERNI  
EXTERNAL FUSES

**POWER INVERTER 1000**  
Potenza massima **1000W** Max power  
Spunto massimo **2000W** Peak power

**74515**

Scatola / Box 4



FULMEN®

B A T T E R I E S

Grazie alla grande esperienza Exide® maturata nello sviluppo e produzione di batterie di primo equipaggiamento per le principali case automobilistiche nasce il marchio Fulmen® che ha introdotto la nuova generazione di batterie di alta qualità per il mercato dell'aftermarket. La nuova gamma è stata progettata per supportare le più recenti tecnologie, tra cui Start-Stop e recupero energetico.

Thanks to the extensive Exide® experience gained in the development and production of first-class batteries for the leading car manufacturers, the Fulmen® brand has been launched to introduce the new generation of high quality batteries for the aftermarket. The new range has been designed to support the latest technologies, including Start-Stop and Energy Recovery.

## Formula Xtreme

Grazie all'applicazione esclusiva di Fulmen di additivi di carbonio sulle piastre negative, le batterie della linea "Formula Xtreme Carbon Boost" si ricaricano fino a 1.5 volte più velocemente e sono progettate per resistere a temperature estreme ed applicazioni con elevato equipaggiamento di bordo.

The new Formula Xtreme Carbon Boost battery recharges up to 1.5 times faster due to the application of carbon additives on the negative plates. The Formula Xtreme Carbon Boost battery is designed to withstand extreme temperature, power-hungry electrical equipment and intensive urban driving.

- 30% di potenza di avviamento in più.
- Si ricarica fino a 1,5 volte più velocemente, grazie alla tecnologia Carbon Boost.
- Ideale per automobili altamente equipaggiate con motori potenti e significative esigenze energetiche.
- Ideale per condizioni climatiche severe e per una guida prolungata in città.
- Rispetta le specifiche di primo equipaggiamento.
- Gamma completa che copre circa il 90% del parco.
- 30% extra starting power.
- Recharges up to 1.5 times faster
- Ideal for highly equipped cars with powerful engines and demanding electrical needs.
- Ideal for extreme weather and urban driving conditions.
- Meets OE requirements.
- Comprehensive range covering around 90% of car parc.



3Dx Grid Technology



Super Fast Recharge



Superior Power



Superior Equipment



Extreme Climate

Coperchio brevettato per una **sicurezza estrema**  
Patented Labyrinth for **extreme safety**

Piastra con **griglia 3DX** avvolta da separatore di polietilene ad alta efficienza

Plate with **3DX grid** enveloped with high performance polyethylene separator



Piastra negativa con **griglia 3DX e speciali additivi di Carbonio**  
Negative plate with **3DX grid and unique carbon additives**

Stato di carica  
State of charge

+1,5 carica più veloce  
faster recharge

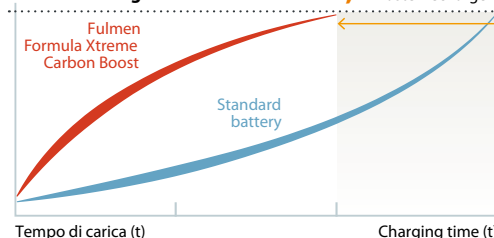

La linea Formula Xtreme Carbon Boost ha migliorato la capacità di carica rendendola fino a 1,5 volte più veloce rispetto alle batterie standard. La ricarica veloce riduce notevolmente il rischio di guasti aiutando la batteria a restare in buono stato di salute, più a lungo.

Formula Xtreme Carbon Boost has improved charge acceptance and recharges up to 1.5 times faster than standard batteries. Fast recharging considerably reduces the risk of breakdowns by helping the battery retain a healthy state of charge for longer.



## Formula

La batteria Fulmen Formula è un prodotto studiato per la maggior parte dei veicoli moderni, con equipaggiamento standard e per utilizzo quotidiano. Come ogni batteria Fulmen, la batteria Formula utilizza le piastre con griglia 3DX avvolte da separatore di polietilene ad alta efficienza per prestazioni elettriche migliori e una maggiore durata.

The proven Fulmen Formula battery is an all-rounder for most modern vehicles, standard equipment and everyday driving. As every Fulmen battery, the Formula battery also features the robust 3DX grid technology for better electrical performance and longer lifespan.

- 15% di potenza di avviamento in più.
- Range completo che copre il 100% del parco auto.
- Prodotta con le specifiche di primo impianto.
- Ideale per veicoli moderni.
- 15% extra starting power.
- Complete range covering 100% of car parc.
- Original equipment experience inside.
- Ideal for modern vehicles.



3Dx Grid  
Technology



Medium  
Power



Standard  
Equipment

## Standard



3Dx Grid  
Technology

- Ideale per le automobili con richiesta energetica di base.
- Ideal for cars with basic power needs.



## 3DX Grid

### Il segreto in ogni batteria Fulmen The secret in every Fulmen battery

La maglia a forma di diamante della griglia 3DX garantisce che la massa attiva rimanga fissa sulla griglia, garantendo prestazioni elettriche migliori e maggiore durata della carica.

The reinforced 3D diamond mesh ensures that the active mass stays fixed on the mesh, resulting in better electrical performance and longer lifespan.



Altre griglie  
Other grid

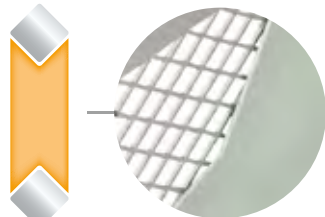

Griglia 3DX  
3DX Grid

- Capacità di adesione superiore della massa attiva, per una maggiore durata.
- Migliore conducibilità elettrica per una maggiore potenza di alimentazione.
- Leghe di pura qualità speciali per massimizzare la durata e prestazioni elevate.
- Elevata resistenza alle vibrazioni e alla corrosione.
- Produzione ecologica.
- Elevata qualità costante grazie al processo di produzione completamente automatizzato.
- Superior active mass adhesion for longer service life.
- Improved electrical conductivity for higher power delivery.
- Special pure quality alloys for maximum lifespan and performance.
- High resistance to vibration and corrosion.
- Eco-friendly production.
- Consistent high quality due to fully automated manufacturing process.

# Start-Stop AGM



Le batterie Start-Stop di Fulmen con tecnologia AGM a combinazione dei gas (VRLA) offrono significativi miglioramenti nell'accettazione di carica, un'alta resistenza ai cicli di carica e sono completamente ermetiche alla fuoriuscita di gas ed elettrolita. Utilizzano componenti e materiali con alte performance, inclusi i separatori in microfibra di vetro a superficie estesa, leghe al piombo-stagno all'avanguardia ed esclusivi additivi a base di carbonio nella materia attiva. Sono l'ideale per le automobili con sistema Start-Stop, sistema di recupero dell'energia in frenata e veicoli che richiedono l'installazione all'interno dell'abitacolo come servizi ed equipaggiamenti dei camper e veicoli di ultima generazione.

Fulmen's Start-Stop AGM battery uses high-performance components and materials, including high-surface glass mat separators, advanced lead-tin alloys and unique carbon additives in the active mass. It is ideally suited to cars with Start-Stop and/or regenerative braking systems. This new-generation AGM battery also offers significantly improved charge acceptance and cycle life.



3DX Grid Technology



Absorbent Glass Mat



Regenerative Braking



Superior Power



Intensive Use



4X Standard Cyclability

- Ottima durata in tutte le condizioni.
- Resistenza al ciclaggio 4 volte superiore ad una batteria standard.
- Ottimizzata per supportare operazioni con stato di carica parziale.
- Ideale per veicoli con sistema Start-Stop ed equipaggiamento elettrico ad alto assorbimento di energia.
- Massima sicurezza perchè sigillata alla fuoriuscita dell'elettrolita e dei gas (ottimale per installazione all'interno del veicolo).
- Valvole di ricombinazione gas VRLA (batteria regolata da valvole).
- Ultima generazione approvata dai costruttori di auto.
- Grande copertura del parco auto con un limitato numero di referenze.

- Long shelf life under all conditions.
- Now 4 times higher cycle life.
- Optimised for partial state of charge operations.
- Ideal for vehicles with Start-Stop system and high electrical absorption.
- Top-level safety features because it is sealed against electrolyte and gas leaks (optimal for installation inside the vehicle)
- Recombinant VRLA (valve regulated).
- Latest generation approved by car manufacturers.
- Great car parc coverage from a limited number of SKUs

**Doppio coperchio di sicurezza** termosaldato con sfioro dei gas e pastiglia rompifiamma  
Sealed **double security lid** with degassing outlet and flame arrestor

Gruppo piastre con **elevata compressione**  
Tall plate group with **high compression**

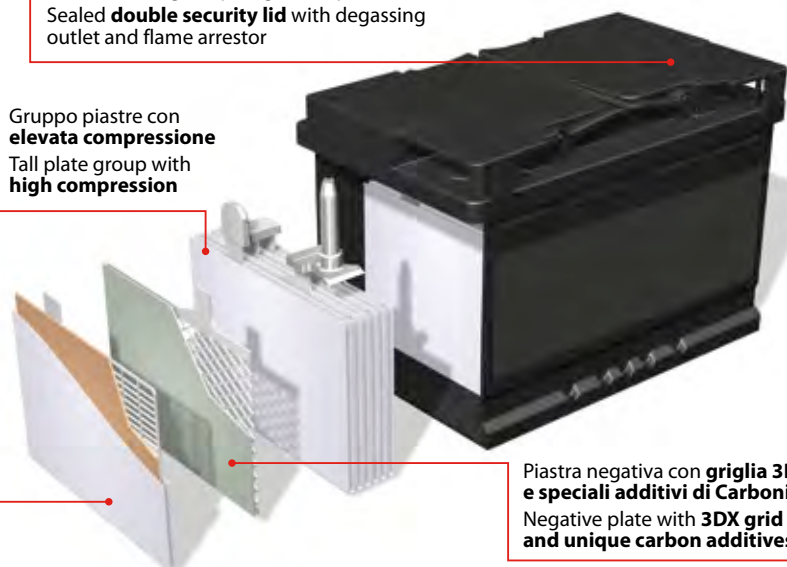

Piastra negativa con **griglia 3DX e speciali additivi di Carbonio**  
Negative plate with **3DX grid and unique carbon additives**

Piastra positiva con griglia incorniciata con **lega altamente tecnologica**.  
Separator in lana di vetro ad elevata capillarità  
Positive plate with framed grid with **high-tech alloy**.  
High-capillarity glass mat separator.



## Key Performances

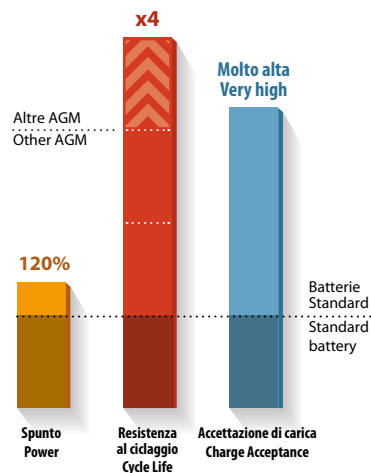

# Start-Stop EFB



L'ultima generazione di batterie EFB offre significativi miglioramenti nell'accettazione di carica e nella resistenza al ciclaggio, grazie agli sforzi compiuti dalla ricerca e sviluppo con l'innovazione della composizione delle leghe di piombo e degli additivi di carbonio. Le batterie EFB di Fulmen supportano i sistemi Start-Stop, i dispositivi per il recupero dell'energia in frenata ed altre tecnologie per il risparmio di carburante.

The latest-generation EFB battery offers significantly improved charge acceptance and cycle life, a result of key breakthroughs in lead alloys and unique carbon additives that came from our research and development efforts. Fulmen's start-stop EFB batteries enable Start-Stop, regenerative braking and other powerful fuel-saving features.



3DX Grid Technology



Regenerative Braking



Superior Power



Intensive Use



3X Standard Cyclability

- Ottima durata in tutte le condizioni.
- Nuova generazione tre volte più resistente al ciclaggio rispetto ad una batteria standard.
- Ottimizzata per supportare operazioni con stato di carica parziale.
- Ideale per veicoli con sistema Start-Stop ed equipaggiamento elettrico ad alto assorbimento di energia.
- Sicura perchè sigillata alla fuoriuscita dell'elettrolita.
- Ultima generazione approvata dai costruttori di auto.
- Grande copertura del parco auto con un contenuto numero di referenze.

- Long shelf life under all conditions.
- Now 3 times higher cycle life.
- Optimised for partial state of charge operations.
- Ideal for vehicles with Start-Stop system and high electrical absorption.
- Safe because it is sealed against electrolyte leaks.
- Latest generation approved by car manufacturers.
- Great car parc coverage from a limited number of SKUs

**Doppio coperchio di sicurezza** termosaldato con sfiato dei gas e pastiglia rompifiamma  
Sealed **double security lid** with degassing outlet and flame arrestor

Gruppo piastre con **media compressione**  
Tall plate group with **medium compression**

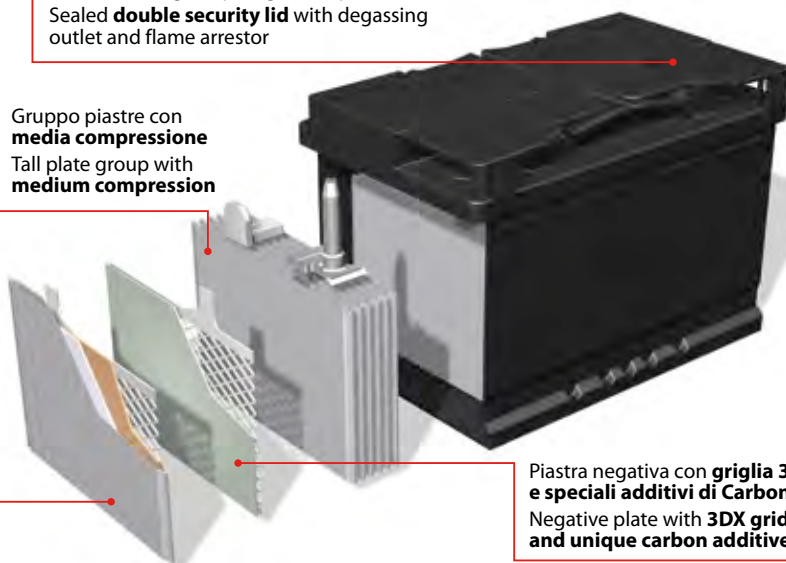

Piastra negativa con **griglia 3DX e speciali additivi di Carbonio**  
Negative plate with **3DX grid and unique carbon additives**

Piastra positiva con griglia 3DX e **pellicola di ritenzione** della materia attiva in **lana di vetro**  
Positive plate with **3DX grid and advanced glass mat retainer** covering active mass

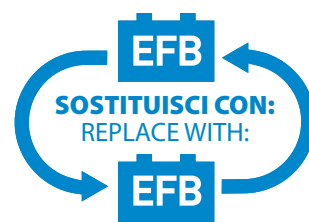

## Key Performances

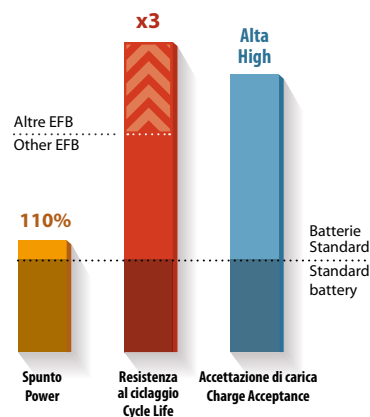

# Formula Xtreme

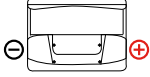
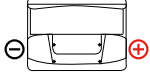
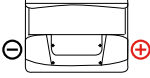
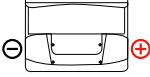

**Batterie 12V per autovetture e veicoli commerciali. Senza manutenzione. Fornite cariche e pronte all'uso.**  
12V batteries for cars and commercial vehicles. No maintenance. Ready to use.

Codice Code	Equivalente a Equivalent to	Capacità (Ah) Capacity (Ah)	Spunto (A) Power (A)	Dimensioni (mm) Dimensions (mm)	Peso (kg) Weight (kg)	Tipo Type	Attacco base Base fitment	Schema montaggio Installation drawing
<b>EXFA530</b>	FA530 EA530 TA530	53	540	207x175x190	13,40	L01	B13	
<b>EXFA640</b>	FA640 EA640 TA640	64	640	242x175x190	15,60	L02	B13	
<b>EXFA770</b>	FA770 EA770 TA770	77	760	278x175x190	18,10	L03	B13	
<b>EXFA1000</b>	FA1000 EA1000 TA1000	100	900	353x175x190	23,00	L05	B13	

# Formula

**Batterie 12V per autovetture e veicoli commerciali. Senza manutenzione. Fornite cariche e pronte all'uso.**  
12V batteries for cars and commercial vehicles. No maintenance. Ready to use.

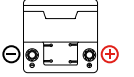
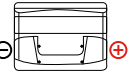
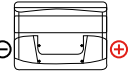
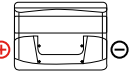
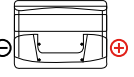
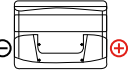
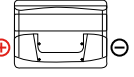
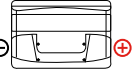
Codice Code	Equivalente a Equivalent to	Capacità (Ah) Capacity (Ah)	Spunto (A) Power (A)	Dimensioni (mm) Dimensions (mm)	Peso (kg) Weight (kg)	Tipo Type	Attacco base Base fitment	Schema montaggio Installation drawing
<b>EXFB440</b>	FB440 EB440 TB440	44	400	175x175x190	11,00	L00	B13	
<b>EXFB442</b>	FB442 EB442 TB442	44	420	207x175x175	11,40	LB1	B13	
<b>EXFB500</b>	FB500 EB500 TB500	50	450	207x175x190	12,40	L01	B13	
<b>EXFB501</b>	FB501 EB501 TB501	50	450	207x175x190	12,60	L01	B13	
<b>EXFB602</b>	FB602 EB602 TB602	60	540	242x175x175	14,00	LB2	B13	
<b>EXFB620</b>	FB620 EB620 TB620	62	540	242x175x190	14,70	L02	B13	
<b>EXFB621</b>	FB621 EB621 TB621	62	540	242x175x190	15,10	L02	B13	
<b>EXFB712</b>	FB712 EB712 TB712	71	670	278x175x175	16,20	LB3	B13	

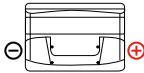
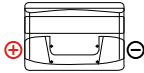
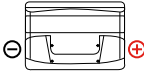
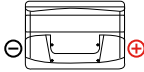
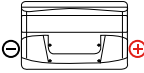
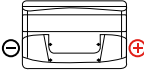
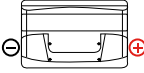
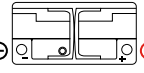
Codice Code	Equivalente a Equivalent to	Capacità (Ah) Capacity (Ah)	Spunto (A) Power (A)	Dimensioni (mm) Dimensions (mm)	Peso (kg) Weight (kg)	Tipo Type	Attacco base Base fitment	Schema montaggio Installation drawing
<b>EXFB740</b>	FB740 EB740 TB740	74	680	278x175x190	17,40	L03	B13	
<b>EXFB741</b>	FB741 EB741 TB741	74	680	278x175x190	17,40	L03	B13	
<b>EXFB800</b>	FB800 EB800 TB800	80	640	315x175x190	19,10	L04	B13	
<b>EXFB802</b>	FB802 EB802 TB802	80	700	315x175x175	18,60	LB4	B13	
<b>EXFB852</b>	FB852 EB852 TB852	85	760	353x175x175	20,10	LB5	B13	
<b>EXFB950</b>	FB950 EB950 TB950	95	800	353x175x190	22,10	L05	B13	
<b>EXFB1000</b>	FB1000 EB1000 TB1000	100	720	315x175x205	22,40	LH4	B13	
<b>EXFB1100</b>	FB1100 EB1100 TB1100	110	850	392x175x190	26,30	L06	B13	

### Range batterie giapponesi / Japan batteries range

<b>EXFB356A</b>	FB356A EB356A TB356A	35	240	187x127x220	8,90	B19	Korean B1 long	 poli piccoli
<b>EXFB356</b>	FB356 EB356 TB356	35	240	187x127x220	8,90	B19	B0	 poli piccoli
<b>EXFB357</b>	FB357 EB357 TB357	35	240	187x127x220	8,90	B19	B0	 poli piccoli
<b>EXFB450</b>	FB450 EB450 TB450	45	330	220x135x225	10,90	E02	B1	
<b>EXFB451</b>	FB451 EB451 TB451	45	330	220x135x225	10,90	E02	B1	
<b>EXFB454</b>	FB454 EB454 TB454	45	330	237x127x227	11,40	B24	B0	
<b>EXFB455</b>	FB455 EB455 TB455	45	330	237x127x227	11,40	B24	B0	
<b>EXFB456</b>	FB456 EB456 TB456	45	330	237x127x227	11,30	B24	B0	 poli piccoli
<b>EXFB457</b>	FB457 EB457 TB457	45	330	237x127x227	11,30	B24	B0	 poli piccoli

continua...  
continue...

...segue Formula...  
... follows Formula...

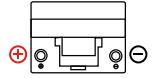
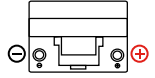
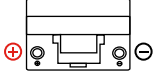
Codice Code	Equivalente a Equivalent to	Capacità (Ah) Capacity (Ah)	Spunto (A) Power (A)	Dimensioni (mm) Dimensions (mm)	Peso (kg) Weight (kg)	Tipo Type	Attacco base Base fitment	Schema montaggio Installation drawing
<b>EXFB504</b>	FB504 EB504 TB504	50	360	200x173x222	13,00	D20	Korean B1	
<b>EXFB505</b>	FB505 EB505 TB505	50	360	200x173x222	13,00	D20	Korean B1	
<b>EXFB604</b>	FB604 EB604 TB604	60	390	230x173x222	15,00	D23	Korean B1	
<b>EXFB605</b>	FB605 EB605 TB605	60	390	230x173x222	15,00	D23	Korean B1	
<b>EXFB704</b>	FB704 EB704 TB704	70	540	270x173x222	17,40	D26	Korean B1+B6	
<b>EXFB705</b>	FB705 EB705 TB705	70	540	270x173x222	17,40	D26	Korean B1+B6	
<b>EXFB954</b>	FB954 EB954 TB954	95	720	306x173x222	21,60	D31	Korean B1	
<b>EXFB955</b>	FB955 EB955 TB955	95	720	306x173x222	21,60	D31	Korean B1	

## Standard

**Batterie 12V per autovetture e veicoli commerciali. Senza manutenzione. Fornite cariche e pronte all'uso.**  
12V batteries for cars and commercial vehicles. No maintenance. Ready to use.

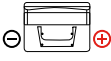
Codice Code	Equivalente a Equivalent to	Capacità (Ah) Capacity (Ah)	Spunto (A) Power (A)	Dimensioni (mm) Dimensions (mm)	Peso (kg) Weight (kg)	Tipo Type	Attacco base Base fitment	Schema montaggio Installation drawing
<b>EXFC400</b>	FC400 EC400 TC400	40	320	175x175x190	9,90	L00	B13	
<b>EXFC440</b>	FC440 EC440 TC440	44	360	207x175x190	11,60	L01	B13	

# Start-Stop AGM

**Batterie 12V per autovetture e veicoli commerciali. Senza manutenzione. Fornite cariche e pronte all'uso.**  
 12V batteries for cars and commercial vehicles. No maintenance. Ready to use.

Codice Code	Equivalente a Equivalent to	Capacità (Ah) Capacity (Ah)	Spunto (A) Power (A)	Dimensioni (mm) Dimensions (mm)	Peso (kg) Weight (kg)	Tipo Type	Attacco base Base fitment	Schema montaggio Installation drawing
<b>EXFK600</b>	FK600 EK600 TK600	60	680	242x175x190	17,90	L02	B13	
<b>EXFK700</b>	FK700 EK700 TK700	70	760	278x175x190	20,70	L03	B13	
<b>EXFK800</b>	FK800 EK800 TK800	80	800	315x175x190	23,50	L04	B13	
<b>EXFK950</b>	FK950 EK950 TK950	95	850	353x175x190	26,00	L05	B13	

# Start-Stop EFB

**Batterie 12V per autovetture e veicoli commerciali. Senza manutenzione. Fornite cariche e pronte all'uso.**  
 12V batteries for cars and commercial vehicles. No maintenance. Ready to use.

Codice Code	Equivalente a Equivalent to	Capacità (Ah) Capacity (Ah)	Spunto (A) Power (A)	Dimensioni (mm) Dimensions (mm)	Peso (kg) Weight (kg)	Tipo Type	Attacco base Base fitment	Schema montaggio Installation drawing
<b>EXFL600</b>	FL600 EL600 TL600	60	640	242x175x190	17,60	L02	B13	
<b>EXFL700</b>	FL700 EL700 TL700	70	720	278x175x190	18,90	L03	B13	
<b>EXFL800</b>	FL800 EL800 TL800	80	720	315x175x190	22,80	L04	B13	

## Tipologie base di fissaggio per auto - Cars fitting base type

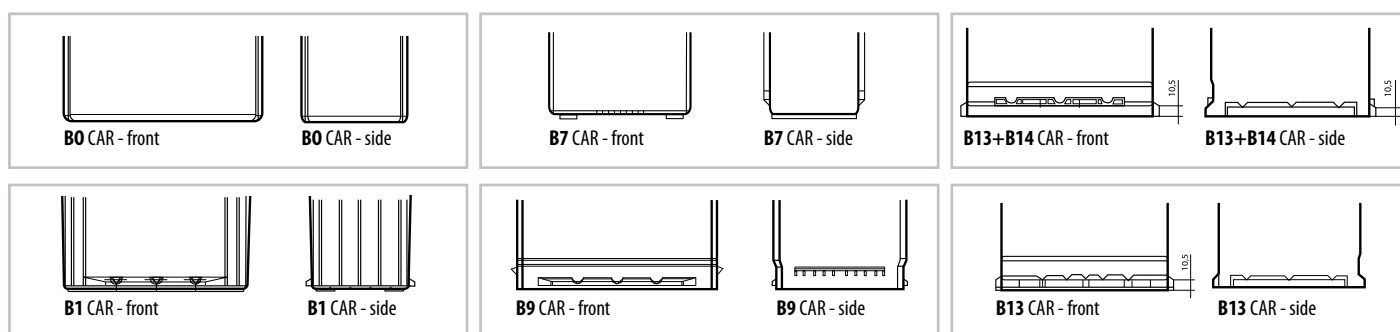

# Standard



## CAVI BATTERIA STANDARD

Pinze di sicurezza completamente isolate  
Lunghezza cavi 250 cm  
Borsa custodia in nylon con cerniera e maniglia  
Libretto istruzioni con manuale di sicurezza

## STANDARD BOOSTER CABLES

Fully insulated clamps  
Cables length 250 cm  
Nylon pouch with zip and handle  
Safety instruction manual included



**70114** 250 cm - 70 A - 2,1 mm<sup>2</sup>

Per motori a benzina fino a 2000 cc  
For petrol engines up to 2000 cc

Borsina / Bag 10

**70115** 250 cm - 100 A - 5,8 mm<sup>2</sup>

per motori a benzina fino a 2000 cc  
for petrol engines up to 2000 cc

Borsina / Bag 10

**70116** 250 cm - 200 A - 12,5 mm<sup>2</sup>

per motori a benzina oltre 2000 cc  
per motori diesel fino a 2000 cc  
for petrol engines above 2000 cc  
for diesel engines up to 2000 cc

Borsina / Bag 10

# Europa



## CAVI BATTERIA EUROPA

Cavi batteria omologati a norma europea DIN 72553  
Pinze di sicurezza completamente isolate in ABS antiurto  
Cavi conformi norma DIN ISO 72551  
Borsa custodia in nylon con cerniera e maniglia  
Libretto istruzioni con manuale di sicurezza

## EUROPA BOOSTER CABLES

DIN 72553 and GS-TÜV approved booster cables  
Fully Insulated ABS clamps  
Flexible cables conform to DIN ISO 72551 norms  
Nylon pouch with zip and handle  
Safety instruction manual included



**70117** 300 cm - 230 A - 16 mm<sup>2</sup>

per motori a benzina fino a 2500 cc  
for petrol engines up to 2500 cc

Borsina / Bag 5

**70118** 350 cm - 350 A - 25 mm<sup>2</sup>

per motori a benzina fino a 5500 cc  
per motori diesel fino a 3000 cc  
for petrol engines up to 5500 cc  
for diesel engines up to 3000 cc

Borsina / Bag 5

**70119** 450 cm - 490 A - 35 mm<sup>2</sup>

per motori a benzina fino a 7000 cc  
per motori diesel fino a 4000 cc  
for petrol engines up to 7000 cc  
for diesel engines up to 4000 cc

Borsina / Bag 4



# Export Series



**CAVI BATTERIA EXPORT 12V**

Con pinze di sicurezza isolate. Molla delle pinze in acciaio temperato per una presa sicura sui poli batteria. Completati di pratica borsa/custodia

**EXPORT BOOSTER CABLES 12V**

Nylon pouch with zip and handle

**70122** 250 cm - 200 A - 6 mm<sup>2</sup>

Borsina / Bag 5



# Export Series



**CAVI BATTERIA EXPORT 12/24V**

Molla delle pinze in acciaio temperato per una presa sicura sui poli batteria. Completati di pratica borsa/custodia

**EXPORT BOOSTER CABLES 12/24V**

Nylon pouch with zip and handle

**70129** 250 cm - 400 A - 12 mm<sup>2</sup>

Borsina / Bag 5



# Export Series



**CAVI BATTERIA EXPORT 12/24V**

Con pinze di sicurezza isolate. Molla delle pinze in acciaio temperato per una presa sicura sui poli batteria. Completati di pratica borsa/custodia

**EXPORT BOOSTER CABLES 12/24V**

Nylon pouch with zip and handle

**70123** 450 cm - 500 A - 22,7 mm<sup>2</sup>

Borsina / Bag 5



**CAVI BATTERIA CON PINZE ISOLATE, 12V**

Pinze con luce a led per una facile identificazione dei poli della batteria e avvio sicuro in situazioni di scarsa illuminazione. I led si attivano all'apertura delle pinze e si disattivano al collegamento alla batteria.

**BOOSTER CABLES WITH INSULATED SAFETY CLAMPS, 12V**

Led clamp lights for easy identification of the battery poles and safe starting in low light situations. The led lights will go on automatically when clamps are opened and will turn off when clamps are closed

**70120** 300 cm - 400 A - 12mm<sup>2</sup>

Borsina / Bag 5





**MICRO-CLIPS, SET 4 PINZETTE ISOLATE**

Pinze di precisione isolate per tester e batterie. Multiuso

**MICROCLIPS, SET 4 BATTERY CLAMPS**

Precision insulated battery testing clips. Multi use.

**70035** 4,5 cm

D/Blister 10 / 200



**COPPIA PINZE BATTERIA  
BATTERY CLAMPS**

**70124** 7 cm - 40A

D/Blister 10 / 120

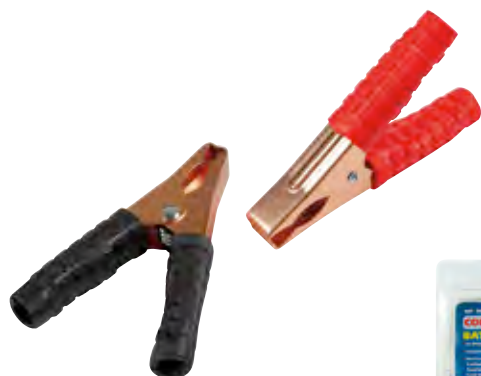

**COPPIA PINZE BATTERIA  
BATTERY CLAMPS**

**70126** 10 cm - 60A

D/Blister 10 / 80



**COPPIA PINZE BATTERIA  
BATTERY CLAMPS**

**70121** 15 cm - 120A

D/Blister 10 / 60



**SICUR-CLAMP PINZE BATTERIA ISOLATE  
SICUR-CLAMP INSULATED BATTERY  
CLAMPS**

**70125** 10 cm - 60A

D/Blister 5 / 50



**SICUR-CLAMP PINZE BATTERIA ISOLATE  
SICUR-CLAMP INSULATED BATTERY  
CLAMPS**

**70127** 14 cm - 120A

D/Blister 10 / 40



**MORSETTO STACCABATTERIA**

Interruttore universale per tutte le batterie standard di autoveicoli. Permette di scollegare la batteria rapidamente e facilmente per preservare la carica durante le lunghe soste, come antifurto o per manutenzione. È sufficiente installare questo interruttore sul polo negativo della batteria.

**BATTERY ISOLATOR SWITCH**

Fits all standard size automotive batteries. Enables to quickly and easily disconnect the battery of the vehicle for preserving the charge during long parking, for safety, for servicing or maintenance.

**39115**

D/Blister 6 / 48

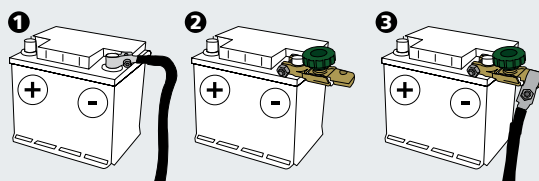

**COPPIA MORSETTI BATTERIA STANDARD  
STANDARD TYPE BATTERY CLAMPS**

**70030**

D/Blister 10 / 100



**MORSETTI BATTERIA RAPID  
Per collegarsi e scollegarsi dalla batteria senza alcun utensile.**

**QUICK RELEASE BATTERY TERMINALS**  
To connect and disconnect the terminals without the use of any tool.

**70032**

D/Blister 10 / 100



**PULISCI-MORSETTI BATTERIA 3 IN 1**

Per la pulizia dei poli batteria e morsetti  
**3-IN-1 BATTERY POST AND TERMINAL CLEANER**

**70021**

D/Blister 12 / 72



**COPPIA MORSETTI BATTERIA MODELLO EUROPA  
BATTERY CLAMPS EUROPE TYPE**

**70040**

D/Blister 10 / 100



# Power Capacitor

**BOOST 1200 A**

## AVVIATORE D'EMERGENZA CON TECNOLOGIA POWER CAPACITOR, 12V

- Recupera in poco tempo, la corrente necessaria per l'avvio del motore dalla batteria parzialmente scarica del veicolo in panne.
- Se la batteria del veicolo in panne è completamente scarica, Power Capacitor avvia il motore utilizzando la corrente di backup interna.
- La tecnologia Capacitor garantisce una lunghissima vita all'avviatore, essendo in grado di sopportare migliaia di cicli di ricarica senza perdere efficacia o capacità di accumulo.
- Per tutti i veicoli a benzina e per Diesel di piccola e media cilindrata.

## JUMP STARTER WITH POWER CAPACITOR TECHNOLOGY, 12V

- Supercapacitors quickly accumulate considerable amounts of energy from the partially discharged battery of the vehicle to be started and then pump it back all in a few seconds allowing the starting of the vehicle from which they absorbed the charge.
- Its internal backup battery can also recharge the starter in case the battery of the vehicle to recharge is too low.
- The Capacitor technology guarantees the Jump Starter a very long life, being able to withstand thousands of re-charging cycles without losing effectiveness or capacity of accumulation.
- For all petrol vehicles and for small and medium-powered diesel vehicles



CON BATTERIA DI BACKUP WITH BACKUP BATTERY



**70167**

Scatola / Box 5

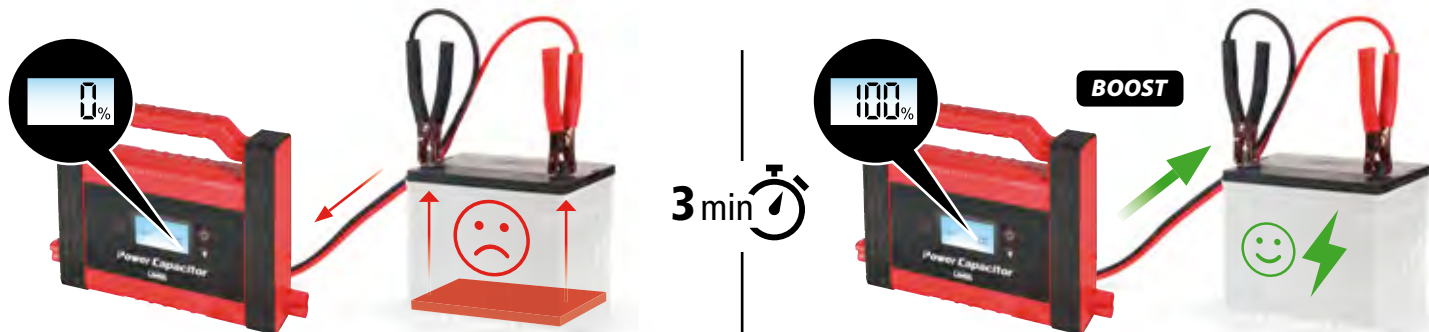

### MODALITÀ DI CARICA FUNZIONE BOOST - BOOST CHARGING MODES

**1** Batteria o veicolo di soccorso  
Battery or emergency vehicle

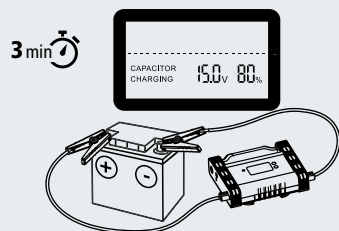

**2** Batteria di backup interna  
Backup battery

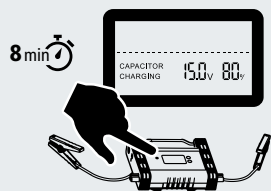

**3** Presa accendisigari  
Cigarette lighter

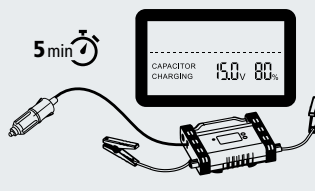

**4** Caricatore USB  
USB Charger

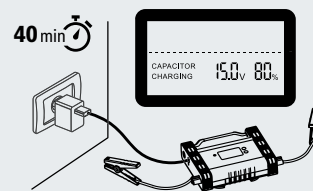

**IL KIT INCLUDE:**

Spinotto per presa accendisigari (12V - 10A)



Caricatore e cavo Micro USB (5V - 2A)



POWER CAPACITOR		POWER CAPACITOR
Uscita	12V	Output
Corrente di picco	1200A	Peak current
Carica da batteria auto 12V	3 min	Charging from 12V car battery
Carica da batteria di backup	8 min	Charging from backup battery
Carica da presa accendisigari	5 min	Charging from lighter socket
Carica da presa USB 5V 2A	40 min	Charging from USB 5V 2A
BATTERIA DI BACKUP		BACKUP BATTERY
Capacità batteria di backup	6000 mAh	Backup battery capacity
Ricarica da presa USB 5V 2A	4 h	Charging time from USB 5V 2A
Ricarica da presa accendisigari	50 min	Charging time from lighter socket
SPECIFICHE:		SPECIFICATIONS:
Dimensioni	295 x 219 x 81 mm	Dimension
Peso	2000 g	Weight
Temperatura di utilizzo	-20°C / +60°C	Operating Temperatures

# Power Pack

## P24-PRO

24Ah

### POWER PACK, AVVIATORE DI EMERGENZA, 12/24V

Per auto, suv, furgoni, camper, camion, mezzi agricoli con centralina elettronica

a 6 protezioni per prevenire:

- Corto circuiti tra le pinze.
- Inversione di polarità.
- Inversione carica.
- Sovraccarica.
- Sovra-scaricamento.
- Sovra-riscaldamento

### POWER PACK, JUMP STARTER, 12/24V

For gasoline and diesel cars, suv, vans, motorhomes, trucks, agricultural vehicles.

Includes 6 smart protections:

- Short-circuit.
- Reverse polarity.
- Over-discharge.
- Reverse-charge.
- Over-temperature.
- Over-charge

**70176 P24-PRO**  
**70168 P35-PRO**

Scatola / Box  5



## P35-PRO

35Ah



SPECIFICHE:	P24PRO	P35PRO	SPECIFICATIONS:
Batteria	Litio/Lithium	Litio/Lithium	Battery
Capacità batteria	24000 mAh	35000 mAh	Capacity
Corrente di avvio (picco) 12V	500A (1000A)	600A (1200A)	12V start (peak) current
Corrente di avvio (picco) 24V	250A (500A)	300A (600A)	24V start (peak) current
Dimensioni	230 x 220 x 75 mm	292 x 233 x 79 mm	Dimension
Peso	1700 g	2700 g	Weight
Ingresso	15V - 1A	15V - 2A	Input
Ricarica spinotto 12V	Si	No	12V recharge
Ricarica trasformatore 230V	Si	Si	230V recharge
Tempo di ricarica	16 h	8 h	Charging time
Temperatura di utilizzo	-20°C / +60°C	-20°C / +60°C	Operating Temperatures



# Power Pack



## MULTI-FUNCTION



### POWER-PACK MULTI-FUNCTION, 12V - 18Ah - 600A START

- **Avviatore di emergenza** 12V per moto, auto, suv, furgoni, camper...  
Con centralina di controllo per la protezione contro l'errato collegamento o inversione di polarità.
- **Caricabatteria** per cellulari, notebooks, laptop e tutti i dispositivi elettronici con batterie ricaricabili.
- **Batteria** per alimentare cellulari, notebooks e altre apparecchiature funzionanti con connessione usb 5V e tutti gli accessori comunemente collegabili allo spinotto per presa accendisigari 12V oppure computer portatili a 19V.
- **Torcia a led** con luce fissa e luce intermittente.  
5 led per il monitoraggio del livello di carica della batteria.

### POWER-PACK MULTI-FUNCTION, 12V - 18Ah - 600A START

- **12V powerful jump starter** for motorcycles, gasoline and diesel cars, suv, vans, motorhomes... Includes smart protection device on connecting clamps to prevent polarity reverse.
- **Battery charger** for phones, notebooks, laptop and all electrical devices with rechargeable batteries.
- **Power bank** supplying power to all electrical and electronic devices commonly connected via usb 5V or car cigarette lighter socket 12V or portable computer up to 19V.
- **LED torch** with flasher functions.  
5 led monitoring of the battery charge level

**70172 18Ah - 600A**

Scatola / Box ☐ 10

IN	230V		
	12V	Standard	1 A
OUT	1 x 12V	Booster	600 A
	1 x 19V	Notebook	65 W max
	1 x 12V	Jack	10 A max
	2 x 5V	USB	3 A tot
Batteria	18 Ah Lithium		
Tempo ricarica	8 h		
Dimensioni	230 x 87 x 27 mm - 615 gr		

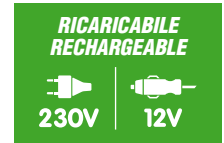

### CONTENUTO DEL KIT KIT INCLUDES



# Power Pack

## JUMP-STARTERS



- **Avviatore di emergenza 12V** per auto, moto, suv, furgoni, camper...
- **Caricabatteria**, per caricare cellulari, notebooks, e tutti i dispositivi elettronici ricaricabili.
- **Batteria** per alimentare cellulari, notebooks e altre apparecchiature funzionanti con connessione USB 5V e tutti gli accessori comunemente collegabili allo spinotto per presa accendisigari 12V.
- **Torcia a led** con luce fissa e 2 luci intermittenti. Display lcd retroilluminato per il monitoraggio del livello carica della batteria e delle funzioni accessorie. Centralina di controllo con 6 protezioni contro: inversione di carica, inversione polarità, basso voltaggio, sovraccarico, surriscaldamento, corto circuito.

- **Powerful 12V jump starter** for cars, motorcycles, suv, vans, motorhomes...
- **Battery charger** for phones and all electrical devices with rechargeable batteries.
- **Power bank** supplying power to all electrical and electronic devices commonly connected via USB 5V or car cigarette lighter socket 12V.
- **Led torch** with 2 flasher functions. Lcd display for monitoring the level of the battery and accessory functions. Mosfet technology with 6 protections against: reverse charge, reverse polarity, low voltage, over-current, over-temperature, short circuit.

TABELLA COMPARATIVA	MOTO	AUTO					FURGONI
		CITYCAR	PICCOLE	MEDIE	GRANDI	SUV	
70164 (400A)	●	●●	●●	●●	●	●	
70162 (400A)	●	●●	●●	●●	●●	●	
70163 (600A)	●	●●	●●	●●	●●	●●	●
70172 (600A)	●	●●	●●	●●	●●	●●	●

La tabella di compatibilità fornisce solo una indicazione approssimata della capacità di avviamento. Diversi fattori possono comunque contribuire a supportare o contrastare l'avviamento di emergenza. (condizioni batteria, impianto elettrico, temperatura, alimentazione, condizioni motore, cilindrata...)  
 ● = Benzina ● = Diesel

### P18-PRO

70163 18Ah - 600A

Scatola / Box 3 / 6

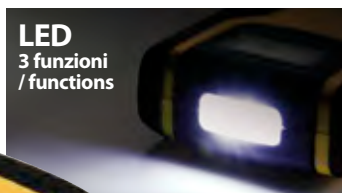

IN	230V		
	12V	Standard	1 A
OUT	1 x 12V	Max	600 A
		Contin.	300 A
	1 x 12V	Jack	10 A
	2 x 5V	USB	4 A total
Batteria	18 Ah Lithium		
Carica	7 / 8 h		
Dimens.	205x98x45 mm - 690 gr		



- 1 Custodia con cerniera
- 2 Unità Power-Pack
- 3 Kit connessione a batteria con pinze isolate e centralina di controllo
- 4 Alimentatore 12V per presa accendisigari
- 5 Alimentatore di rete 230V presa domestica
- 6 Cavetto con presa accendisigari per uscita 12V

### P12-PRO

70162 12Ah - 400A

Scatola / Box 5 / 10

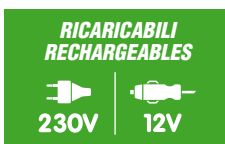

IN	230V		
	12V	Standard	1 A
OUT	1 x 12V	Max	400 A
		Contin.	200 A
	1 x 12V	Jack	10 A
	1 x 5V	USB	2,1 A
Batteria	12 Ah Lithium		
Carica	5 / 6 h		
Dimens.	162x78x33 mm - 440 gr		



## P8-GUMMY

70164 7,5Ah - 400A

Scatola / Box 3 / 12



- Avviatore di emergenza 12V
- Caricabatteria
- Batteria

In solido alluminio con rivestimento in gomma antiurto ed antigraffio, idoneo per utilizzo in ambienti umidi e difficili. Mosfet Technology, 6 protezioni contro: inversione di carica, di polarità, basso voltaggio, sovraccarico, surriscaldamento, corto circuito.

- Jump starter 12V
- Battery charger
- Power Bank

Strong aluminium housing with gummy shell for extreme protection. Heavy duty model, suitable for use in severe conditions. Mosfet Technology, 6 protections against: reverse charge, reverse polarity, low voltage, over-current, over-temperature, short circuit.



<b>IN</b>	USB (1 A)		
<b>OUT</b>	1 x 12V	Max	400 A
		Contin.	200 A
	1 x 5V	USB	2,1 A
<b>Batteria</b>	7,5 Ah Lithium		
<b>Carica</b>	5 / 6 h		
<b>Dimens.</b>	133x78x33 mm - 390 gr		



- |  |   |
|--|---|
| 1 Custodia con cerniera  | 1 Zip bag   |
| 2 Unità Power-Pack   | 2 Power-Pack unit   |
| 3 Kit connessione a batteria con pinze isolate e centralina di controllo | 3 Battery connection kit with smart protection and insulated clamps |
| 4 Cavo USB > Micro USB   | 4 USB > Micro USB cable   |

### EASY 2 START, AVVIATORE CARICABATTERIA

- In circa 15/20 minuti fornisce alla batteria lo spunto necessario ad avviare il veicolo.
- È sufficiente collegare gli spinotti alle prese accendisigari delle due auto (cavo da 5 m).
- Idoneo per veicoli fino a 2700 cc.
- Auto-switch, universale per tutti i tipi di batteria.
- Regolazione automatica della corrente per la totale sicurezza.
- I led indicano il flusso di corrente e lo stato della carica

### EASY 2 START, CAR-TO-CAR CHARGER AND BOOSTER

- Boosts vehicle batteries up to 2700 cc in under 15-20 minutes.
- Charging is conducted through the cigarette sockets of the non operating vehicle and the donor vehicle.
- The charger includes 5 meters of cable

70137

D/Blister 6 / 24



Per veicoli fino a:  
For vehicles up to:  
**2700 cc**





# Turbo



**70104** 12V 4A 12>120 Ah

Scatola / Box ☐ 12



**70106** 12V 6A 16>150 Ah

Scatola / Box ☐ 12

**TURBO, CARICABATTERIA**  
 Conforme alle normative europee.  
 Doppio isolamento e protezione automatica di sovraccarica.  
 Protezione contro l'inversione di polarità.  
 Led di indicazione dello stato di carica.  
 Compatto e facilmente trasportabile.

**TURBO, BATTERY CHARGER**  
 With led indicators

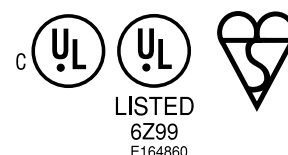

**Funzione  
 Mantenimento**

**70108** 6V 2A 4>30 Ah  
 6V 8A 30>150 Ah  
 12V 2A 2>20 Ah  
 12V 8A 20>150 Ah

Scatola / Box ☐ 6



**Funzione  
 Mantenimento**

**70109** 6V 2A 4>36 Ah  
 6V 12A 36>150 Ah  
 12V 2A 2>26 Ah  
 12V 12A 26>220 Ah

Scatola / Box ☐ 6

Quando la batteria è stata ricaricata, la **funzione di mantenimento** emette una carica a basso amperaggio che permette di lasciare la batteria continuamente sotto carica per avere sempre la batteria al 100%.

Once the battery has been recharged, the service function produces a low amperage charge in order to keep battery constantly on charge and 100% operative.

Articolo	TURBO			
	70104	70106	70108	70109
Voltaggio	12V	12V	6V / 12V	6V / 12V
Carica rapida	4A	6A	8A	12A
Carica di mantenimento	-	-	2A	2A
Struttura	Plastica	Plastica	Plastica	Plastica
Indicatore di carica	Led	Led	Led	Led
Fusibile di protezione	si	si	si	si
Doppio isolamento	si	si	si	si
Gestione elettronica	-	-	-	-
Protezioni elettriche	si	si	si	si
Selettore di carica	-	-	si	si



# Pro-Charger

## PRO-CHARGER, CARICABATTERIA

Robusto involucro in metallo con impugnatura per trasporto. Isolamento protettivo. Protezione automatica contro l'inversione di polarità, cortocircuito e sovraccarico.

Amperometro, cavo alimentazione 230V da 2 metri, cavetti di ricarica da 1,2 metri con morsetti. Omologato e conforme alle norme europee.

## PRO-CHARGER, BATTERY CHARGER

Sturdy metal-sheet covering  
Protective insulation  
Protections against polarity inversion and overcharge  
Ampere gauge  
Lead (approx.2 m) with a plug  
Charging lead (approx. 1,2 m) with clips



**70105** 12V 5A 5>150 Ah

Scatola / Box ☐ 6



**70107** 6V 1A 4>30 Ah  
6V 9A 30>120 Ah  
12V 1,2A 3,7>30 Ah  
12V 6,5A 30>150 Ah

Scatola / Box ☐ 6



Gestione elettronica



**70110** 12V 12A 26>220 Ah

Scatola / Box ☐ 6

Funzione Mantenimento

Quando la batteria è stata ricaricata, la **funzione di mantenimento** emette una carica a basso amperaggio che permette di lasciare la batteria continuamente sotto carica per avere sempre la batteria al 100%.

Once the battery has been recharged, the service function produces a low amperage charge in order to keep battery constantly on charge and 100% operative.



Articolo	PRO-CHARGER		
	70105	70107	70110
Voltaggio	12V	6V / 12V	12V
Carica rapida	5A	9A (6V) / 6,5A (12V)	12A
Carica mantenimento	-	0,85A (6V) / 1,2A (12V)	-
Struttura	Metallo	Metallo	Metallo
Indicatore di carica	Amperom.	Amperom.	Amperom.
Fusibile di protezione	si	si	si
Doppio isolamento	si	si	si
Gestione elettronica	-	-	si
Protezioni elettriche	si	si	si
Selettore di carica	-	si	-

**AMPEROMATIC, CARICABATTERIA INTELLIGENTE**

- Struttura in ABS completamente sigillata ed impermeabile, idonea anche per l'utilizzo esterno.
- Con protezioni contro scintille, corti circuiti, surriscaldamento ed inversione di polarità.
- Universale per tutte le batterie al Piombo, SM, Gel e AGM con capacità da 4-120 Ah
- Compatibile con vetture dotate del sistema Start & Stop
- Clips per batteria e kit ad anelli per collegamento rapido
- Microprocessore con 4 diverse modalità di carica

**AMPEROMATIC, INTELLIGENT BATTERY CHARGER**

- ABS structure completely sealed and waterproof, suitable for outdoor use
- With spark protection, short circuit, and polarity reversal protection, with temperature and voltage compensation
- Microprocessor with 4 different charging modes
- Universal for lead and gel batteries with capacities ranging from 4-120 Ah
- Compatible with vehicles equipped with "Start & Stop" system
- Battery clamps and M6 eyelet



**IP65**

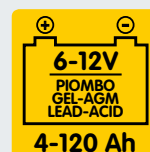

**SISTEMA DI CONNESSIONE RAPIDO**  
Clips + kit ad anelli per batteria  
**QUICK CONNECT SYSTEM**  
Battery clamps + M6 Eyelet



# Amperomatic DIGIT

**4,2A 6 STEP**

<b>70180</b>	6V	0,8A	4>120 Ah
	12V	0,8A	4>120 Ah
	12V	4,2A	4>120 Ah

D/Blister  6 / 12



6V standard  
7,3V / 0,8A

12V soft  
14,5V / 0,8A



12V standard  
14,5V / 4,2A

12V freddo - cold  
14,7V / 4,2A



# Amperomatic

**4,2A 6 STEP**

<b>70179</b>	6V	0,8A	4>120 Ah
	12V	4,2A	4>120 Ah

D/Blister  6 / 12

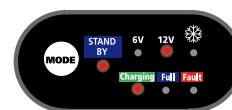

6V standard  
7,3V / 0,8A

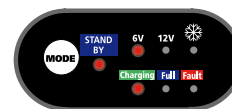

12V standard  
14,5V / 4,2A

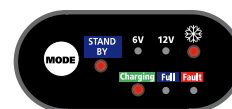

12V freddo - cold  
14,7V / 4,2A

# Amperomatic TRAINER

**1A 5 STEP**

<b>70178</b>	6V	0,55A	4>120 Ah
	12V	1A	4>120 Ah

D/Blister  6 / 12



**A - Mantenimento**  
Pulse maintenance



**B - Modalità di carica**  
Charge mode

Articolo	70180	70179	70178
Voltaggio	6V / 12V	6V / 12V	6V / 12V
Carica rapida	4,2A (step)	4,2A (step)	1,0A (step)
Carica di mantenimento	0,8A (step)	0,8A (step)	1,0A (step)
Struttura	ABS imperm. IP65	ABS imperm. IP65	ABS imperm. IP65
Gestione processo di carica	Microprocessore	Microprocessore	Microprocessore
Indicatore di carica	Digital display	Led	Led

# Amperomatic Lithium-Plus

## AMPEROMATIC LITHIUM-PLUS, CARICABATTERIA INTELLIGENTE

- Controllato da microprocessore, ideale per veicoli a 12V
- Tipi di batteria: 12V GEL/STD, AGM, Litio.
- Con modello di ricarica invernale selezionabile.
- Funzione di ricarica continua.
- Funzione di diagnosi e ricarica per batterie scariche fino a 7,5V.
- Varie funzioni di protezione

## AMPEROMATIC LITHIUM-PLUS, INTELLIGENT BATTERY CHARGER

- Microprocessor controlled, ideal for 12V vehicles.
- Battery type: 12V GEL/STD, AGM, Lithium.
- Winter charging model can be chose.
- Continuous maintenance charging function.
- Diagnosis and rescue function for deeply discharged batteries to 7,5V.
- Various protection functions

**70177** 12V 3,8A 1,2>120 Ah

D/Blister 6 / 12



**3,8A 6 STEPS**

- 1 Identificazione batteria / battery type check
- 2 Carica "soft" / soft charge
- 3 Carica "massima" / max charge
- 4 Carica costante / float charge
- 5 Analisi batteria / battery analyze
- 6 Mantenimento ad impulsi / pulse maintenance

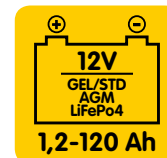

Adatto anche per batterie al litio:  
Suitable also for:  
**LiFePo4**  
batteries



**SISTEMA DI CONNESSIONE RAPIDO**  
Clips + kit ad anelli per batteria  
**QUICK CONNECT SYSTEM**  
Battery clamps + M6 Eyelet

## UNI TRAINER, ALLENATORE AUTOMATICO PER BATTERIE 12V - 300 mA

- Mantiene la batteria efficiente e sempre pronta
- Funzione di carica (300 mA) e di scarica (100 mA)
- Per tutti i tipi di batterie con capacità da 4 a 120 Ah
- Alimentazione 230V
- Protezione contro i corto circuiti

## UNI TRAINER, BATTERY TRAINER - 300 mA

- Keeps your batteries always ready to perform
- For Gel and Agm batteries
- Active charging and discharging
- For 12V / 4-120 Ah batteries
- 230V / 50 Hz mains voltage (14W)
- Charge current 300 mA RMS
- Discharge current 100 mA RMS
- With short-circuit protection

**70175**

Scatola / Box 10 / 50



**SISTEMA DI CONNESSIONE RAPIDO**  
Clips per batteria + kit ad anelli per batteria  
**QUICK CONNECT SYSTEM**  
Battery clamps + M6 Eyelet



# Smart-Led



Sostituiscono i fusibili tradizionali. Il Led si accende quando il fusibile è bruciato, rendendo facile la sua individuazione.

Replaces traditional fuses. Fuse integrated with Led which glows when fuse is blown.



**SMART LED, SET 6 FUSIBILI LAMELLARI CON SPIA A LED, 12/32V**  
**SMART-LED, SET 6 INDICATOR PLUG-IN FUSES, 12/32V**

Blister 25 / 500

<b>70181</b>	5A	<b>70185</b>	20A
<b>70182</b>	7,5A	<b>70186</b>	25A
<b>70183</b>	10A	<b>70187</b>	30A
<b>70184</b>	15A		

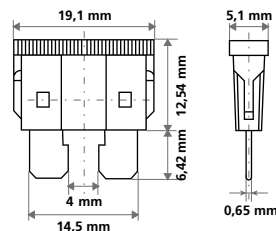

**SMART LED, SET 6 MICRO-FUSIBILI LAMELLARI CON SPIA A LED, 12/32V**  
**SMART-LED, SET 6 INDICATOR MICRO-BLADE FUSES, 12/32V**

Blister 25 / 500

<b>70189</b>	5A	<b>70193</b>	20A
<b>70190</b>	7,5A	<b>70194</b>	25A
<b>70191</b>	10A	<b>70195</b>	30A
<b>70192</b>	15A		

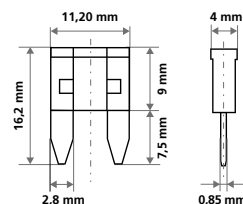

**Assortiti**



**SMART LED, MIX 10 FUSIBILI LAMELLARI CON SPIA A LED, 12/32V**  
**SMART-LED, MIX 10 INDICATOR PLUG-IN FUSES, 12/32V**

**70188**

Blister 25 / 500

<b>5A</b>	1 pz	<b>20A</b>	2 pz
<b>7,5A</b>	1 pz	<b>25A</b>	2 pz
<b>10A</b>	1 pz	<b>30A</b>	1 pz
<b>15A</b>	2 pz		

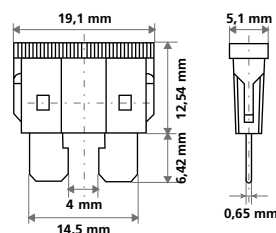

**Assortiti**



**SMART LED, MIX 10 MICRO-FUSIBILI LAMELLARI CON SPIA A LED, 12/32V**  
**SMART-LED, MIX 10 INDICATOR MICRO-BLADE FUSES, 12/32V**

**70196**

Blister 25 / 500

<b>5A</b>	1 pz	<b>20A</b>	2 pz
<b>7,5A</b>	1 pz	<b>25A</b>	2 pz
<b>10A</b>	1 pz	<b>30A</b>	1 pz
<b>15A</b>	2 pz		

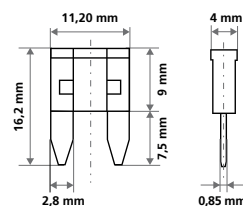

**SET 10 FUSIBILI LAMELLARI  
MICRO-LOW PROFILE, 12/32V**  
**SET 10 MICRO-LOW PROFILE FUSES, 12/32V**

**70084**

Blister 50 / 500



5A	1 pz
7,5A	1 pz
10A	2 pz
15A	2 pz
20A	2 pz
25A	1 pz
30A	1 pz

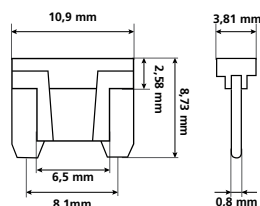

**SET 10 MICRO-FUSIBILI  
LAMELLARI ASSORTITI, 12/32V**  
**SET 10 ASSORTED MICRO-BLADE  
FUSES, 12/32V**

**70085**

Blister 50 / 500

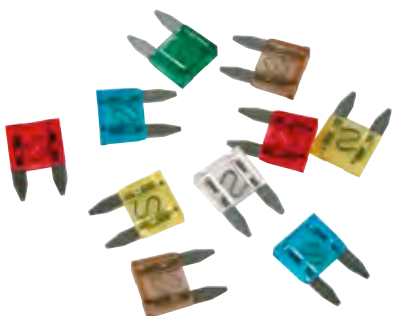

7,5A	2 pz
10A	2 pz
15A	2 pz
20A	2 pz
25A	1 pz
30A	1 pz

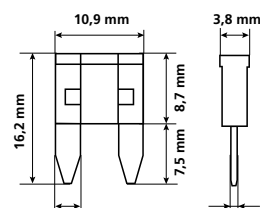

**SET 6 FUSIBILI LAMELLARI ASSORTITI, 12/32V**  
**SET 6 ASSORTED PLUG-IN FUSES, 12/32V**

**70070**

Blister 50 / 500

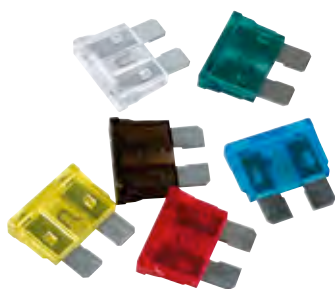

7,5A	1 pz
10A	1 pz
15A	1 pz
20A	1 pz
25A	1 pz
30A	1 pz

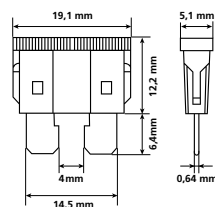

**SET 10 FUSIBILI LAMELLARI ASSORTITI, 12/32V**  
**SET 10 ASSORTED PLUG-IN FUSES, 12/32V**

**70080**

Blister 50 / 500

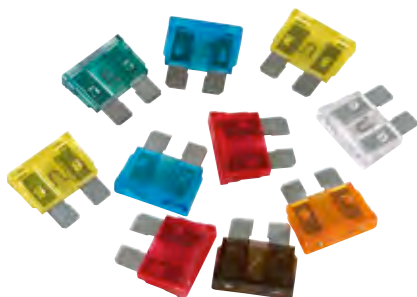

5A	1 pz
7,5A	1 pz
10A	2 pz
15A	2 pz
20A	2 pz
25A	1 pz
30A	1 pz

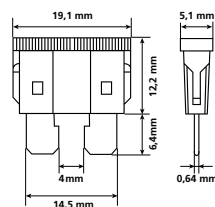

**SET 10 MICRO FUSIBILI LAMELLARI MICRO-DUE ASSORTITI, 12/32V**  
**SET OF 10 ASSORTED MICRO DUE BLADE TYPE FUSES, 12/32V**

**70081**

Scatola / Box 50 / 500

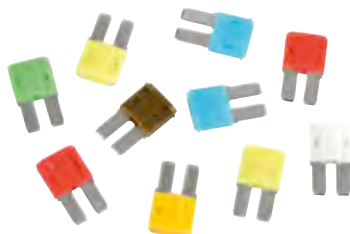

5A	1 pz
7,5A	1 pz
10A	2 pz
15A	2 pz
20A	2 pz
25A	1 pz
30A	1 pz

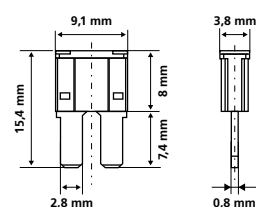



**80**  
pcs

**SET 80 FUSIBILI LAMELLARI, 12/32V**  
**SET 80 PLUG-IN FUSES, 12/32V**

**70042**

Scatola / Box ☐ 10 / 100

5A	10 pz
7,5A	10 pz
10A	20 pz
15A	10 pz
20A	10 pz
25A	10 pz
30A	10 pz



**100**  
pcs

**SET 100 MICRO FUSIBILI LAMELLARI, 12/32V**  
**SET 100 MICRO PLUG-IN FUSES, 12/32V**

Scatola / Box ☐ 10 / 40

<b>69993</b>	5A
<b>69994</b>	7,5A
<b>69995</b>	10A
<b>69996</b>	15A
<b>69997</b>	20A
<b>69998</b>	25A
<b>69999</b>	30A



**50**  
pcs

**CONFEZIONE 50 FUSIBILI LAMELLARI, 12/32V**  
**50 PLUG-IN FUSES, 12/32V**

Scatola / Box ☐ 10 / 40

<b>70043</b>	5A
<b>70044</b>	7,5A
<b>70045</b>	10A
<b>70046</b>	15A
<b>70047</b>	20A
<b>70048</b>	25A
<b>70049</b>	30A



**FUSIBILE LAMELLARE MAXI (1 PZ), 12/32V**  
**MAXI BLADE FUSE (1 PC), 12/32V**

Blister ☐ 10 / 500

<b>70072</b>	20A
<b>70073</b>	30A
<b>70074</b>	40A
<b>70075</b>	50A
<b>70076</b>	60A
<b>70077</b>	70A
<b>70078</b>	80A
<b>70079</b>	100A

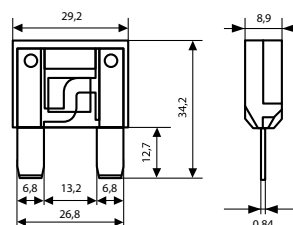

**SET 10 FUSIBILI ASSORTITI, 12/32V**  
**SET 10 ASSORTED FUSES, 12/32V**

**70060**

Blister ☐ 50 / 500

5A	1 pz
8A	4 pz
16A	4 pz
25A	1 pz

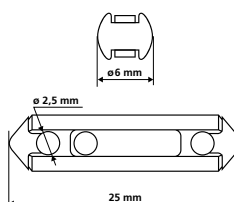



**SET 10 FUSIBILI IN VETRO, 12/32V**  
**SET 10 ASSORTED GLASS FUSES, 12/32V**

**70062**

Blister  50 / 500

<b>5A</b>	1 pz
<b>10A</b>	5 pz
<b>15A</b>	3 pz
<b>20A</b>	1 pz

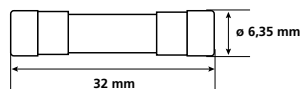

**SET 10 MICRO-FUSIBILI, 12/32V**  
 Conformi alla normativa: IEC 127-2/2 DIN 41661 standard

**SET 10 ZME FUSES, 12/32V**  
 Meet IEC 127-2/2 DIN 41661 standard

**70063**

Blister  50 / 500

<b>1A</b>	1 pz
<b>2A</b>	3 pz
<b>3A</b>	2 pz
<b>5A</b>	3 pz
<b>6,3A</b>	1 pz

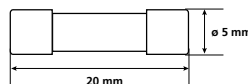

<b>70086</b>	10A
<b>70087</b>	15A
<b>70088</b>	20A
<b>70089</b>	25A
<b>70090</b>	30A
<b>70091</b>	35A
<b>70092</b>	40A
<b>70093</b>	50A
<b>70094</b>	60A
<b>70095</b>	70A
<b>70096</b>	80A

**FUSIBILE AGU IN VETRO (1 PZ), 12/32V**  
 In lega di zinco, contatti in rame laminato oro

**AGU GLASS FUSE (1 PC), 12/32V**  
 Zinc alloy with gold plated copper alloy

Blister  25 / 500

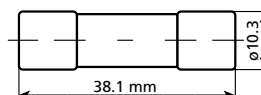

**MAXI+, FUSIBILE LAMELLARE TIPO "ANL" 12/32V**

**MAXI+ "ANL" TYPE BLADE FUSE, 12/32V**

Blister  10 / 500

<b>70067</b>	80A	1 pz
<b>70068</b>	100A	1 pz
<b>70069</b>	130A	1 pz

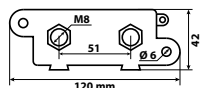
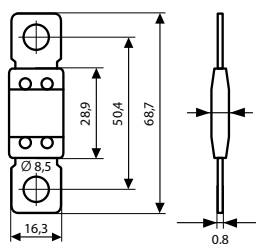

**PORTA-FUSIBILE TIPO "ANL" CON COPERCHIO**

Adatto per fusibile Maxi+ da 40 a 275 A. Fusibile non incluso

**"ANL" FUSE HOLDER**

Suitable for Maxi+ fuse from 40 to 275 A. Fuse not included

**45009**

D/Blister  10 / 100

**Adatto per fusibile Suitable for fuse MAXI+ (40 ÷ 275 A)**







3~30A

**PF-1, PORTA FUSIBILE IN BACHELITE**  
In linea, per fusibili lamellari da 3 a 30 A.  
Cavo da 20 cm

**ATS BAKELITE IN-LINE FUSE HOLDER**  
3~30 A

**45001**Blister  25 / 500

3~20A

**PF-2, PORTA FUSIBILE IN NYLON**  
In linea, per fusibili lamellari  
da 3 a 20 A. Predisposto per  
collegamento tramite capicorda

**ATS NYLON IN-LINE FUSE HOLDER**  
3~20 A

**45002**Blister  50 / 500

10~30A

**PF-3, PORTA FUSIBILE IN PVC**  
In linea, per fusibili lamellari da 10 a 30 A.  
Impermeabile, con coperchio.  
Completo di cavo da 30 cm

**ATS PVC IN-LINE FUSE HOLDER**  
10~30 A

**45003**D/Blister  25 / 500

1~20A

**PF-4, PORTA FUSIBILE IN NYLON**  
In linea, per fusibili in vetro da 1 a 20 A.  
Completo di cavo da 20 cm

**NYLON IN-LINE FUSE HOLDER FOR  
GLASS TUBE FUSE**  
1~20 A

**45004**Blister  25 / 500

5~30A

**PF-5, PORTA FUSIBILE IN BACHELITE**  
In linea, per fusibili in vetro da 5 a 30 A.  
Completo di cavo da 20 cm

**BAKELITE IN-LINE FUSE HOLDER FOR  
GLASS TUBE FUSE**  
5~30 A

**45005**Blister  25 / 500

5~40A

**PF-6, PORTA FUSIBILE IN BACHELITE**  
In linea, per fusibili siluro da 5 a 40 A.  
Completo di cavo da 20 cm

**BAKELITE IN-LINE FUSE HOLDER FOR  
GBC FUSE**  
5~40 A

**45006**Blister  25 / 500

10~80A

**PORTA FUSIBILE AGU**  
In policarbonato, contatti in lega di rame  
laminato oro. Adatto per fusibili da 10A ~ 80A

**POWER FUSE HOLDER**  
Quality fuse holder. Clear polycarbonate with  
gold plated copper alloy.  
For AGU fuses 10A ~ 80A

**45008**D/Blister  10 / 200

**RUBA-CORRENTE PER FUSIBILE LAMELLARE, 12/24V**

Preleva la corrente da qualsiasi porta fusibile lamellare consentendo di alimentare un dispositivo aggiuntivo

**QUICK-CONNECTOR FOR FUSE, 12/24V**

Enables the connectivity and the current withdrawal from any micro-blade fuse holder

**70065** per fusibili Micro - for Micro fuse

**70066** per fusibili Standard - for Standard fuse

D/Blister 20 / 200

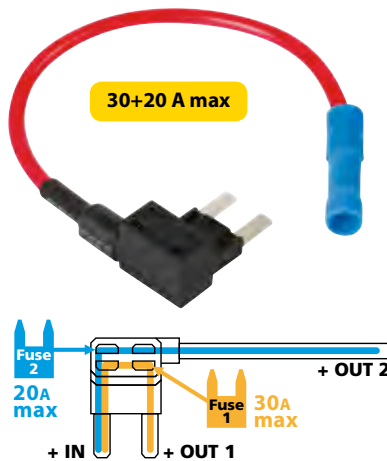

**FUSE BLOCK, SCATOLA PORTAFUSIBILI, 1 ENTRATA - 6 USCITE, 12/24V**

Permette di collegare contemporaneamente 6 apparecchiature ad una unica alimentazione. Le 6 spia a led indicano se il fusibile corrispondente è interrotto. Adatto per fusibili lamellari standard da 5 a 30A

**FUSE BLOCK, 1 INPUT - 6 WAY OUT, FUSE HOLDER, 12/24V**

6 different devices may be connected to one single power source. The 6 led point out when fuse is broken. Suitable for standard blade-fuse from 5 to 30A

**70097**

D/Blister 25 / 100

<b>IN</b>	12/24 V	Vite	
<b>OUT</b>	12/24 V	Faston	100 A tot.

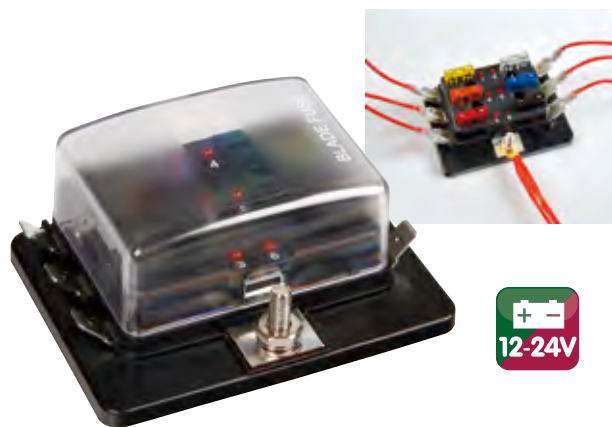

**RELÈ UNIVERSALE 12V - 30A**  
**UNIVERSAL RELAY 12V - 30A**

**45500** 4 contatti / pins

**45501** 5 contatti / pins

D/Blister 10 / 100

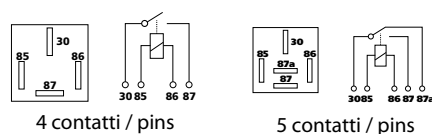

**CAVI ELETTRICI A DUE FILI**  
Universale per auto, moto, camion  
**ELECTRICAL TWIN CORE CABLES**  
Universal for car, motorcycle, trucks

<b>98544</b>	1,5A	0,50 mm <sup>2</sup>	10 m
<b>98543</b>	3A	1,00 mm <sup>2</sup>	10 m
<b>98715</b>	4A	0,75 mm <sup>2</sup>	5 m
<b>98716</b>	8A	1,50 mm <sup>2</sup>	5 m

D/Blister 10 / 50



6,3x0,8 mm



10 pcs



0,5~1,5 mm<sup>2</sup>



10 pcs

**10 TERMINALI - CAPICORDA FEMMINA PIATTI - ROSSO**

Misura 6,3x0,8 mm.  
Preisolati per cavi da 0,5 a 1,5 mm<sup>2</sup>

**FEMALE DISCONNECTS - RED**

**45061**

Blister 10 / 100



**10 TERMINALI - CAPICORDA MASCHIO PIATTI - ROSSO**

Misura 6,3x0,8 mm.  
Preisolati per cavi da 0,5 a 1,5 mm<sup>2</sup>

**MALE DISCONNECTS - RED**

**45071**

Blister 10 / 100



6,3x0,8 mm



10 pcs



1,5~2,5 mm<sup>2</sup>



10 pcs

**10 TERMINALI - CAPICORDA FEMMINA PIATTI - BLU**

Misura 6,3x0,8 mm.  
Preisolati per cavi da 1,5 a 2,5 mm<sup>2</sup>

**FEMALE DISCONNECTS - BLUE**

**45062**

Blister 10 / 100



**10 TERMINALI - CAPICORDA MASCHIO PIATTI - BLU**

Misura 6,3x0,8 mm.  
Preisolati per cavi da 1,5 a 2,5 mm<sup>2</sup>

**MALE DISCONNECTS - BLUE**

**45072**

Blister 10 / 100



Ø 4 mm



10 pcs



0,5~1,5 mm<sup>2</sup>



10 pcs

**10 TERMINALI - CAPICORDA FEMMINA ROTONDI - ROSSO**

Misura Ø 4 mm.  
Isolati per cavi da 0,5 a 1,5 mm<sup>2</sup>

**BULLET RECEPTACLE CONNECTORS - RED**

**45063**

Blister 10 / 100



**10 TERMINALI - CAPICORDA MASCHIO ROTONDI - ROSSO**

Misura Ø 4 mm.  
Preisolati per cavi da 0,5 a 1,5 mm<sup>2</sup>

**BULLET CONNECTORS - RED**

**45074**

Blister 10 / 100



Ø 5 mm



10 pcs



1,5~2,5 mm<sup>2</sup>



10 pcs

**10 TERMINALI - CAPICORDA FEMMINA ROTONDI - BLU**

Misura Ø 5 mm.  
Isolati per cavi da 1,5 a 2,5 mm<sup>2</sup>

**BULLET RECEPTACLE CONNECTORS - BLUE**

**45064**

Blister 10 / 100



**10 TERMINALI - CAPICORDA MASCHIO ROTONDI - BLU**

Misura Ø 5 mm.  
Preisolati per cavi da 1,5 a 2,5 mm<sup>2</sup>

**BULLET CONNECTORS - BLUE**

**45073**

Blister 10 / 100



2,8x0,5 mm



12 pcs

0,5~1,5 mm<sup>2</sup>**12 TERMINALI - CAPICORDA FEMMINA PIATTI - ROSSO**

Misura 2,8x0,5 mm.

Preisolati per cavi da 0,5 a 1,5 mm<sup>2</sup>**FEMALE DISCONNECTS - RED****45065**Blister  10 / 100

Ø 5 mm

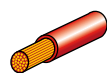

10 pcs

0,5~1,5 mm<sup>2</sup>**10 TERMINALI - CAPICORDA AD ANELLO - ROSSO**

Misura Ø 5 mm.

Preisolati per cavi da 0,5 a 1,5 mm<sup>2</sup>**RING TERMINALS - RED****45066**Blister  10 / 100

Ø 5 mm



10 pcs

1,5~2,5 mm<sup>2</sup>**10 TERMINALI - CAPICORDA AD ANELLO - BLU**

Misura Ø 5 mm.

Preisolati per cavi da 1,5 a 2,5 mm<sup>2</sup>**RING TERMINALS - BLUE****45067**Blister  10 / 100

Ø 5 mm



10 pcs

2,5~6 mm<sup>2</sup>**10 TERMINALI - CAPICORDA AD ANELLO - GIALLO**

Misura Ø 5 mm.

Preisolati per cavi da 2,5 a 6,0 mm<sup>2</sup>**RING TERMINALS - YELLOW****45068**Blister  10 / 100

6,3x0,8 mm

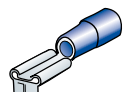

10 pcs

1,5~2,5 mm<sup>2</sup>**10 TERMINALI - CAPICORDA DOPPIO INNESTO****MASCHIO+FEMMINA - BLU**

Misura 6,3x0,8 mm.

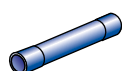
Preisolati per cavi da 1,5 a 2,5 mm<sup>2</sup>**PIGGY BACK DISCONNECTS - BLUE****45070**Blister  10 / 100

10 pcs

1,5~2,5 mm<sup>2</sup>**10 CONNETTORI RAPIDI A PRESSIONE - BLU**Isolati per cavi da 1,5 a 2,5 mm<sup>2</sup>**BUTT CONNECTORS - BLUE****45060**Blister  10 / 1000,5~1,5 mm<sup>2</sup>1,5~2,5 mm<sup>2</sup>**10 CONNETTORI RAPIDI A GHIgliOTTINA - ROSSO / BLU**

(morsetti auto-spellanti) Isolati assortiti:

5 rossi per cavi da 0,5 a 1,5 mm<sup>2</sup>5 blu per cavi da 1,5 a 2,5 mm<sup>2</sup>**STRIPPING QUICK SPLICES - RED/BLUE****45050**Blister  10 / 100

6,3x0,8 mm

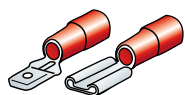

20+20 pcs

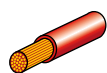

0,5~1,5 mm<sup>2</sup>

**KIT 40 TERMINALI-CAPICORDA PIATTI - ROSSO**

Misura 6,3x0,8 mm. Composto da:  
20 capicorda "maschio",  
20 capicorda "femmina".  
Preisolati per cavi da 0,5 a 1,5 mm<sup>2</sup>

**MALE AND FEMALE DISCONNECTS KIT - RED**

**45051**

Blister 10 / 100



6,3x0,8 mm

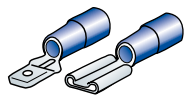

20+20 pcs



1,5~2,5 mm<sup>2</sup>

**KIT 40 TERMINALI-CAPICORDA PIATTI - BLU**

Misura 6,3x0,8 mm. Composto da:  
20 capicorda "maschio",  
20 capicorda "femmina".  
Preisolati per cavi da 1,5 a 2,5 mm<sup>2</sup>

**MALE AND FEMALE DISCONNECTS KIT - BLUE**

**45052**

Blister 10 / 100



6,3x0,8 mm

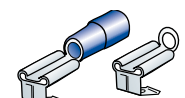

20+20 pcs



1,5~2,5 mm<sup>2</sup>

**KIT 40 TERMINALI-CAPICORDA PIATTI A DOPPIO INNESTO - BLU**

Misura 6,3x0,8 mm. Composto da:  
20 capicorda "maschio",  
20 capicorda "femmina".  
Preisolati per cavi da 1,5 a 2,5 mm<sup>2</sup>

**MALE AND FEMALE PIGGY BACK DISCONNECTS KIT - BLUE**

**45053**

Blister 10 / 100



Ø 4 mm

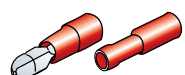

20+20 pcs



0,5~1,5 mm<sup>2</sup>

**KIT 40 TERMINALI-CAPICORDA ROTONDI - ROSSO**

Ø 4 mm. Composto da:  
20 capicorda "maschio",  
20 capicorda "femmina".  
Preisolati per cavi da 0,5 a 1,5 mm<sup>2</sup>

**BULLET AND RECEPTACLE CONNECTORS KIT - RED**

**45056**

Blister 10 / 100



Ø 5 + Ø 6 mm



20+20 pcs



1,5~2,5 mm<sup>2</sup>



2,5~6 mm<sup>2</sup>

**KIT 40 TERMINALI-CAPICORDA AD ANELLO - GIALLO/BLU**

20 capicorda preisolati Ø 5 mm  
per cavi da 1,5 a 2,5 mm<sup>2</sup>  
20 capicorda preisolati Ø 6 mm  
per cavi da 2,5 a 6 mm<sup>2</sup>

**RING TERMINALS KIT - YELLOW/BLUE**

**45057**

Blister 10 / 100



2,8x0,5 mm

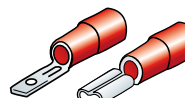

10+10 pcs



0,5~1,5 mm<sup>2</sup>

**KIT 20 TERMINALI-CAPICORDA PIATTI - ROSSO**

Misura 2,8x0,5 mm. Composto da:  
10 capicorda "maschio",  
10 capicorda "femmina".  
Preisolati per cavi da 0,5 a 1,5 mm<sup>2</sup>

**MALE AND FEMALE DISCONNECTS KIT - RED**

**45055**

Blister 10 / 100



6,3x0,8 mm

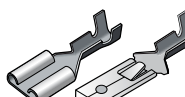

10+10 pcs



0,8~2,0 mm<sup>2</sup>

**KIT 20 TERMINALI-CAPICORDA PIATTI NON ISOLATI**

Misura 6,3x0,8 mm. Composto da:  
10 capicorda "maschio", 10 capicorda "femmina".  
Non isolati per cavi da 0,8 a 2,0 mm<sup>2</sup>  
Adatti per connettori rapidi (art. 45059)

**NON-INSULATED MALE AND FEMALE DISCONNECTS KIT**

**45058**

Blister 10 / 100

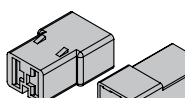

5+5 pcs

**KIT 10 CONNETTORI RAPIDI A 2 VIE PER TERMINALI NON ISOLATI**

Misura 6,3x0,8 mm. Composto da: 5 connettori "maschio", 5 connettori "femmina". Adatti per terminali non isolati (art. 45058)

**KIT 10 RECEPTACLE HOUSING 2 POSITIONS FOR NON-INSULATED DISCONNECTS**

**45059**

Blister 10 / 100



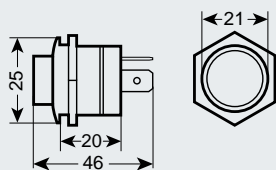

**INTERRUTTORE A PULSANTE CON LED, 12/24V**

5A max. Led a due funzioni: sempre acceso o quando attivato. Terminali faston 6,3x0,8 mm

**BUTTON SWITCH WITH LED, 12/24V**

5A max

<b>45537</b>	Blu	Blue
<b>45538</b>	Rosso	Red
<b>45539</b>	Verde	Green

Blister 10 / 100

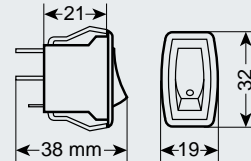

**INTERRUTTORE CON LED, 12/24V**

10A max. Led a due funzioni: sempre acceso o quando attivato. Terminali faston 6,3x0,8 mm

**ROCKER SWITCH WITH LED, 12/24V**

10A max

<b>45540</b>	Blu	Blue
<b>45541</b>	Rosso	Red
<b>45542</b>	Verde	Green

Blister 10 / 100

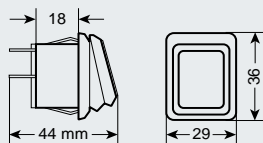

**INTERRUTTORE IMPERMEABILE CON LED, 12/24V**

10A max. Led a due funzioni: sempre acceso o quando attivato. Impermeabile IP65. Terminali faston 6,3x0,8 mm

**ROCKER SWITCH WITH LED, WATERPROOF, 12/24V**

10A max. IP65 waterproof

<b>45531</b>	Blu	Blue
<b>45532</b>	Rosso	Red
<b>45533</b>	Verde	Green

Blister 10 / 100

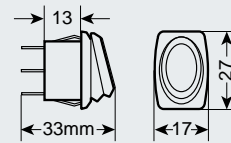

**MICRO INTERRUTTORE IMPERMEABILE CON LED, 12/24V**

10A max. Led a due funzioni: sempre acceso o quando attivato. Impermeabile IP65. Terminali faston 2,8x0,5 mm

**MICRO ROCKER SWITCH WITH LED, WATERPROOF, 12/24V**

10A max. IP65 waterproof

<b>45534</b>	Blu	Blue
<b>45535</b>	Rosso	Red
<b>45536</b>	Verde	Green

Blister 10 / 100

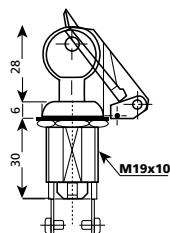

**INTERRUTTORE A CHIAVE**

Foro Ø 19,2 mm  
Spessore max 19 mm  
Terminali a vite o faston 6,3x0,8 mm

**KEY SWITCH**

Hole Ø 19,2 mm  
19 mm max depth

**45550**

Blister 10 / 100

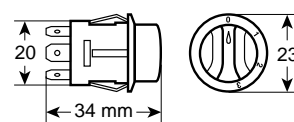

**INTERRUTTORE A ROTAZIONE A 4 POSIZIONI - 12/24V**

Montaggio ad incasso. Universale

**ROTATING SWITCH, 4 POSITIONS - 12/24V**

Recess mounting. Universal

**45566**

Blister 10 / 100



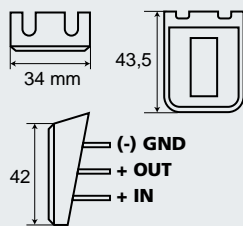

**INTERRUTTORE ILLUMINATO**  
 Con pannello di supporto 42x34 mm, spessore max 2 mm  
**ILLUMINATED ROCKER SWITCH**  
 With panel 42x34 mm.  
 Max depth 2 mm

**45552**

Blister 10 / 100

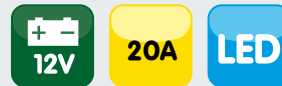
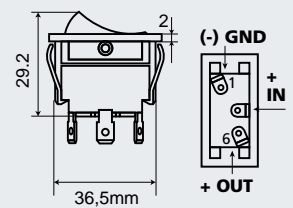

**INTERRUTTORE CON LUCE**  
 Foro 38x22 mm  
**ILLUMINATED ROCKER SWITCH**  
 Hole 38x22 mm

**45553**

Blister 10 / 100

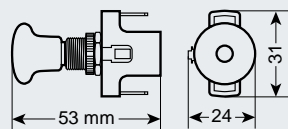

**INTERRUTTORE TIRA-SPINGI A LED**  
 Foro Ø 12,2 mm.  
 Spessore max 6 mm  
**PUSH-PULL SWITCH WITH LED**  
 Hole Ø 12,2 mm. 6 mm max depth

<b>45570</b>	Rosso	Red
<b>45571</b>	Verde	Green
<b>45572</b>	Blu	Blue

Blister 10 / 100

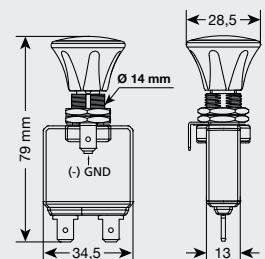

**INTERRUTTORE TIRA-SPINGI, 12/24V**  
 Con spia a Led rosso. Foro Ø 14,2 mm.  
 Spessore di montaggio max 6 mm.  
 50A max  
**PUSH-PULL SWITCH, 12/24V**  
 With red Led light. Hole Ø 14,2 mm.  
 6 mm max mounting depth.  
 50A max

**45569**

Blister 10 / 100

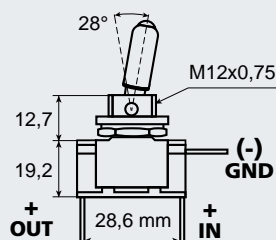

**INTERRUTTORE A LEVA, 2 CONTATTI**  
 In alluminio, con spia a led.  
 Foro Ø 12,2 mm. Spessore max 6 mm  
**TOGGLE SWITCH WITH LED, 2 TERMINALS**  
 With Led. Hole Ø 12,2 mm.  
 6 mm max depth

<b>45557</b>	Rosso	Red
<b>45558</b>	Verde	Green
<b>45559</b>	Blu	Blue

Blister 10 / 100

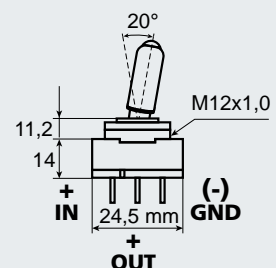

**INTERRUTTORE A LEVA, 3 CONTATTI**  
 In alluminio, con spia a led.  
 Foro Ø 12,2 mm. Spessore max 2 mm  
**TOGGLE SWITCH WITH LED, 3 TERMINALS**  
 With Led. Hole Ø 12,2 mm.  
 2 mm max depth

<b>45554</b>	Rosso	Red
<b>45560</b>	Verde	Green
<b>45561</b>	Blu	Blue

Blister 10 / 100





12V





20A

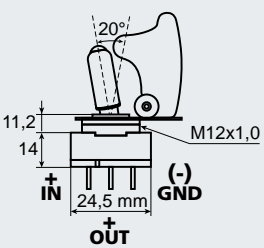

LED



**INTERRUTTORE A LEVA CON SICURA**  
 Con spia a Led in colore coordinato alla sicura. Foro Ø 12,2 mm. Spessore max 10 mm

<b>45556</b>		Rosso	Red
<b>45562</b>		Blu	Blue
<b>45563</b>		Verde	Green

Blister  10 / 100





12-24V



10A





**INTERRUTTORE TIRA-SPINGI**  
 Foro Ø 8,2 mm  
 Spessore max 15,7 mm  
 Terminali a vite

**PUSH-PULL SWITCH**  
 Hole Ø 8,2 mm  
 15,7 mm max depth

**45551**

Blister  10 / 100





12-24V



10A



**INTERRUTTORE A PRESSIONE**  
 Foro Ø 22,2 mm  
 Spessore max 6 mm  
 Terminali faston 6,3x0,8 mm

**STARTER BUTTON SWITCH**  
 Hole Ø 22,2 mm  
 6 mm max depth

**45555**

Blister  10 / 100





E R10



12V



LED

**PANNELLO ACCENSIONE RACING**  
 Pannello accensione con interruttore generale e chiave estraibile; pulsante avviamento motore illuminato; interruttori a leva con sicura e luce spia. Kit pre-assemblato pronto per il collegamento.

**5 IN 1 ALUMINIUM PANEL**  
 1 protected power killer-switch, 1 lighted engine-start switch, 3 protected switches with power-on lights

**45564** 192x67 cm

D/Blister  5 / 20





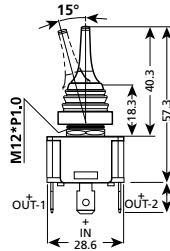

**INTERRUTTORE A LEVA**

Con cuffie intercambiabili. 3 terminali faston 6,3x0,8 mm. Foro Ø 12 mm, spessore max 9 mm. Funzione: acceso 1, spento, acceso 2

**TOGGLE SWITCH**

With interchangeable boots. 3 terminals. Fitting hole Ø 12 mm, 9 mm max mounting depth. On-1, off, on-2 function

**45583**

Blister 10 / 100



**Bipolare  
Bipolar**

**INTERRUTTORE KILLER-SWITCH**

Interruttore "stacca batteria" bipolare tipo competizione. Consente di interrompere il circuito elettrico principale in caso di emergenza. Ideale anche come antifurto o per preservare la batteria quando non si usa il veicolo

**KILLER-SWITCH**

Cuts the battery power. Suitable also as anti-theft or for battery-saving when vehicle is not in use. Bipolar

**39045** 6/12/24V

D/Blister 10 / 100



**EXT-11, INTERRUTTORE STACCA BATTERIA A 3 POSIZIONI, 12/32V**

Interrompe il circuito elettrico principale. Preserva la batteria durante il rimessaggio. Efficace azione di sicurezza ed antifurto. Foro Ø 29 mm. 100A max

**EXT-11, POWER-OFF SWITCHER, 3 FUNCTIONS, 12/32V**

Interrupts the main electric circuit. Preserves the battery during long periods of storage. Safety and antitheft action with removable selector. Hole Ø 29 mm. 100A max

**39081**

D/Blister 25 / 100

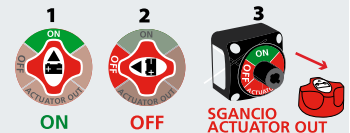
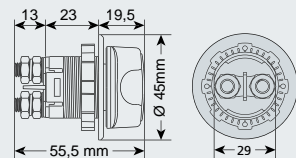
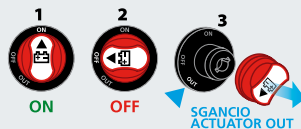

**INTERRUTTORE STACCA BATTERIA A 3 POSIZIONI, 12/50V**

Interrompe il circuito elettrico principale. Preserva la batteria durante il rimessaggio. Efficace azione di sicurezza ed antifurto. 200A max

**POWER-OFF SWITCHER, 3 FUNCTIONS, 12/50V**

Universal. 200A max

**39032**

D/Blister 10 / 60

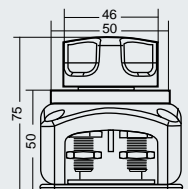
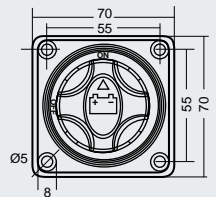

**SPIA A LED ROSSA, 12/24V**  
Foro Ø 14 mm. Spessore di montaggio max 3,5 mm.

**RED LED INDICATOR LIGHT, 12/24V**

Hole Ø 14 mm. 3,5 mm max mounting depth

**45568**

Blister 10 / 100

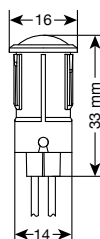

**SPIA A LED, 12/24V**

Foro Ø 11,2 mm. Spessore max da 0,5 a 5 mm

**LED INDICATOR LIGHT, 12/24V**

Hole Ø 11,2 mm. From 0,5 to 5 mm max depth

<b>45580</b>	Rosso	Red
<b>45581</b>	Verde	Green
<b>45582</b>	Blu	Blue

Blister 10 / 100





**POWER-5, CENTRALINA DI COMANDO, ACCENSIONE A 5 USCITE, 12/24V**

Permette di collegare contemporaneamente 5 apparecchiature ad un'unica fonte di corrente. Ogni uscita può essere comandata singolarmente tramite interruttore acceso/spento.

Le 5 spie a led indicano quale delle 5 uscite è alimentata. Cavo da 60 cm.

Base adesiva. Capacità max combinata 5A

**POWER-5, 5 WAY CONTROLLER UNIT, 12/24V**

5 different devices may be connected to one single power-source and each device can be singularly remote-controlled through on/off switch. The 5 Led point out when the power is on. Adhesive base. 5A max combined capacity. 60 cm cable

**98196**

D/Blister 10 / 50

<b>IN</b>	12/24V	Universale	
<b>OUT</b>	5 x 12/24V	Morsetti	5 A tot.
<b>Cavo</b>	60 cm		



Telecomando  
Remote Control

**INTERRUTTORE CON TELECOMANDO 12V**

Per comandare fino a 2 circuiti contemporaneamente. Permette di accendere o spegnere qualsiasi apparecchiatura a 12V fino ad una distanza di circa 30 metri

**ONE-CHANNEL REMOTE-CONTROLLED SWITCH, 12V**

Can control up to 2 circuits simultaneously. Enables to turn on-off any electrical device from up to 30 meters away.

**45592**

D/Blister 5 / 50



**6 IN 1 CONTROLLER-UNIT 12V**

Centralina-Interruttore a 6 canali con variatore di luminosità. Per collegare e comandare singolarmente fino a 6 luci (lampadine o Led) massimo 300 mA ogni uscita.

**6 IN 1 CONTROLLER-UNIT, 12V**

6 channels controller switch with dimmers. For connecting and controlling singularly up to 6 lights (bulbs/Led) max 300 mA each.

**70449**

D/Blister 10 / 100





**TROMBE BITONALI Ø 66 MM, 12V**  
Elettropneumatiche, omologate  
**DOUBLE ELECTROPNEUMATIC HORNS Ø 66 MM, 12V**  
Approved

**42008** 30A, 118 dB, 780/840 Hz

D/Blister  12



**AVVISATORE ACUSTICO BITONALE, Ø 85 MM - 12V**  
Elettromagnetico

**ELECTROMAGNETIC HORNS, Ø 85 MM - 12V**  
High and low accorded notes

**42005** 6A, 105/118 dB, 400/500 Hz

D/Blister  20



22 cm



**VINTAGE, TROMBA ELETTRICA 12V**  
Suono vintage, auto antica

**VINTAGE, ELECTRIC HORN 12V**  
Vintage sound

**42007** 8A, 115 dB, 530 Hz

Scatola / Box  20



**AVVISATORE ACUSTICO Ø 75 MM, 12V**  
Omologato a norme europee  
**Ø 75 MM DISK HORN, 12V**  
With european approval

**42010** 5A, 420 Hz, 105 dB

D/Blister  10 / 50



**AVVISATORE ACUSTICO Ø 90 MM, 12V**  
Omologato a norme europee  
**Ø 90 MM DISK HORN, 12V**  
With european approval

**42011** 5A, 435 Hz, 118 dB Tono alto / high

**42014** 5A, 335 Hz, 105 dB Tono basso / low

D/Blister  10 / 50

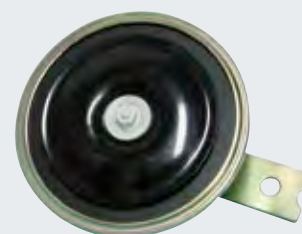

**AVVISATORE ACUSTICO Ø 100 MM, 12V**  
Omologato a norme europee  
**Ø 100 MM DISK HORN, 12V**  
With european approval

**42012** 3,5A, 420 Hz, 110 dB Tono alto / high

**42015** 3A, 380 Hz, 110 dB Tono basso / low

D/Blister  5 / 50



**NOTA IMPORTANTE:** di norma, l'impianto di segnalazione acustica per i veicoli deve essere del tipo bitonale, ovvero composto da un avvisatore a tono alto ed uno a tono basso.

**NOTICE:** To comply with the street regulations, vehicles must be equipped with two-tone horns. Horn set must have 1 piece high tone and one piece low-tone disk.



**SIRENA ELETTRONICA 12V**  
Completa di staffa di montaggio.  
**12V ALARM SIREN**

**42020** 1,2A - 125 dB

D/Blister  5 / 50



**MICROSIRENA UNIVERSALE 6/12V**  
Maxi suono  
**UNIVERSAL 6/12V MICRO SIREN**  
Maxi-sound

**70265** 100 dB

D/Blister  5 / 100



**BACK-UP, ALLARME RETROMARCIA**  
**MULTITENSIONE 12-24-36V**  
Ideale per qualsiasi mezzo stradale, auto,  
camper, bus, camion, macchine lavoro,  
carrelli, scavatori...

**BACK-UP ALARM MULTIVOLTAGE,**  
**12-24-36V**

Suitable for all road vehicles, car, van,  
motorhome, truck, bus, forklift, agricultural  
equipment...

**74217** 97 dB

D/Blister  10 / 60

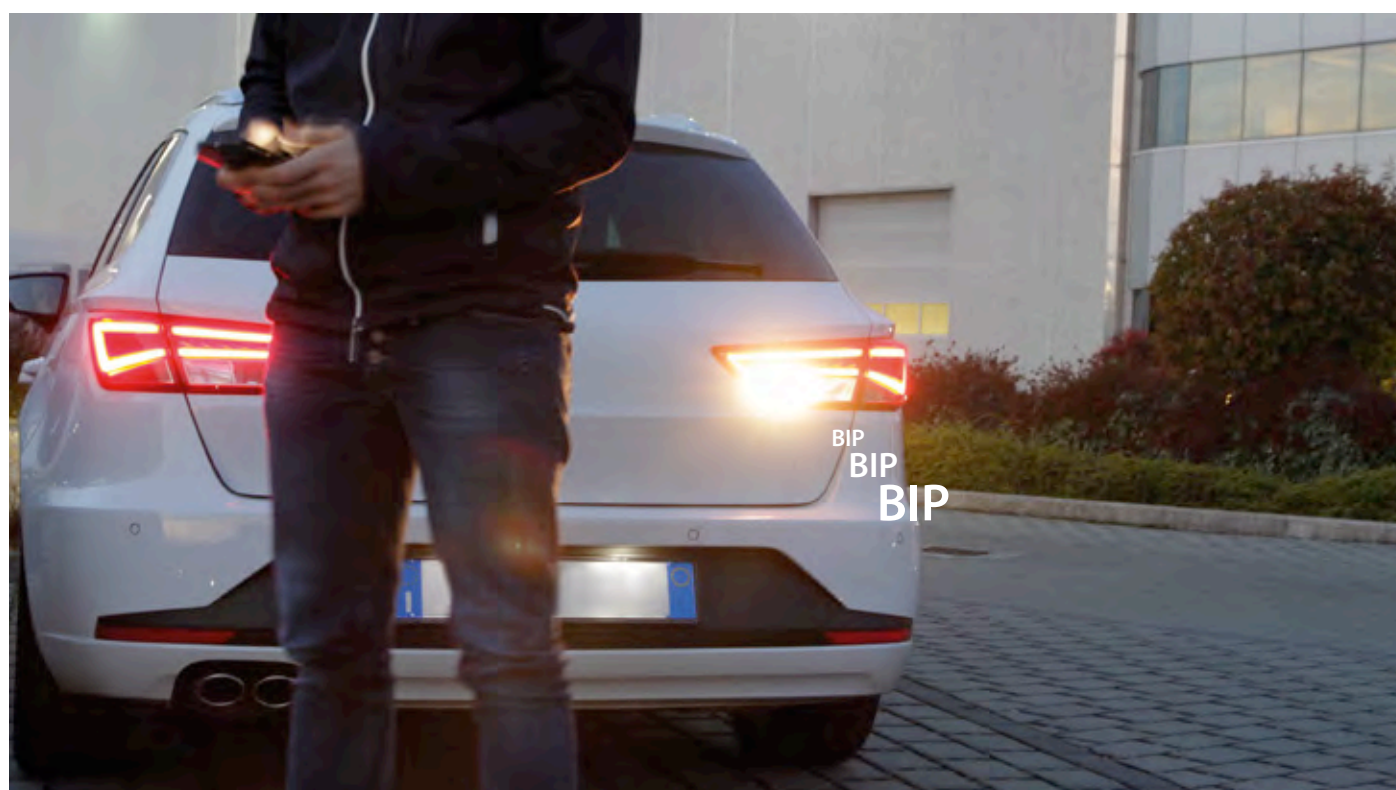



Nota: non utilizzabile su veicoli con gruppi ottici posteriori a Led  
 Note: do not use on vehicles with LED taillights

**RETRO BIP, AVVISATORE ACUSTICO PER RETROMARCIA**

Si applica al fanale tramite biadesivo e si attiva automaticamente quando il fanale retromarcia si illumina. Batteria di lunga durata in dotazione

**RETRO BIP, BACK-UP ALARM**

Alert signal activates when reverse light is turned-on. Easy-fit, simply fix it onto the reverse lamp. No wiring, no drilling required. Long-life battery included.

**74218**

D / Blister 20 / 200



**RETRO-BIP 12V**

Allarme acustico per retromarcia

**RETRO-BIP 12V**

Reversing alarm "beep-beep"

**74213** 110 dB

D/Blister 12 / 144



**BIP-LITE I, 12V**

Lampadina retromarcia da 10W con avvisatore acustico incorporato

**BIP-LITE I, 12V**

10W reverse lamp with beeper function.

**74215** 10W - BA15s

D/Blister 6 / 120

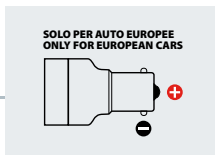

SOLO PER AUTO EUROPEE  
 ONLY FOR EUROPEAN CARS



**Alogena  
 Halogen**

**BIP-LITE II, 12V**

Lampadina retromarcia alogena da 21W con avvisatore acustico incorporato

**BIP-LITE II, 12V**

21W halogen reverse lamp with beeper function

**74216** 21W - BA15s

D/Blister 6 / 120

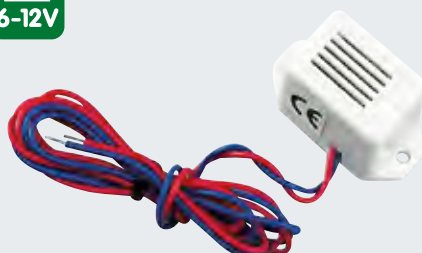

**ALARM IL RICORDA LUCI 6-12V**

Avvisatore acustico per ricordare di spegnere le luci della vettura

**HEADLIGHT REMINDER ALARM 6-12V**

**74212**

Blister 12 / 288



Ø 15 cm (6")



**JUMBO VENTILATORE OSCILLANTE Ø 6" - 12V**  
Griglia e piedistallo in metallo

**JUMBO Ø 6" OSCILLATING METAL CAR FAN - 12V**  
Metal grill and base

**73101** 12V - 12W

D/Blister 4 / 12



Ø 20 cm (8")

PINZA CLIP-FIT



**CHROME-FAN, VENTILATORE Ø 8"**

Con griglia metallica cromata. Funzionamento fisso o oscillante. Con snodo per regolazione orizzontale e verticale del flusso di aria. Spinotto accendisigari con fusibile, interruttore e spia a led. Montaggio fisso con staffa e viti, oppure mobile tramite pinza a clip

**CHROME-FAN Ø 8"**

Fan with chromed grill. Fixed or oscillating function. With swivel joint for an easy adjustment of airflow-direction. Fused cigarette lighter plug with led and on/off switch. With metal base for permanent fitting and plastic clamp for an universal clamp-onto any interior hold

**73111** 12V - 16W

D/Blister 3 / 9



**CHROME-FAN, VENTILATORE CON VENTOSA Ø 8"**

Ventilatore con griglia metallica cromata. Funzionamento fisso o oscillante. Con snodi per una regolazione orizzontale e verticale del flusso di aria. Spinotto tipo tedesco con fusibile interno. Ideale per prese accendisigari standard e tipo Germania. Fissaggio tramite ventosa

**CHROME-FAN WITH SUCTION CUP Ø 8"**

With chromed grill. Fixed or oscillating function. With swivel joints for an easy adjustment of airflow-direction. Cigarette lighter socket with internal fuse. Fits standard and german type sockets. Fixing through suction cup.

**73112** 12V - 16W

D/Blister 3 / 9

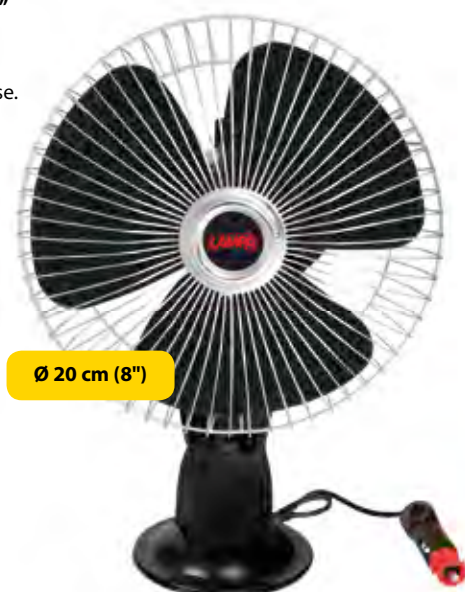

Ø 20 cm (8")

VENTOSA SUCTION-CUP





Con borsa termica

**SCALDA BIBERON, DA VIAGGIO CON BORSA TERMICA, 12V**  
 Scalda e mantiene caldo a lungo biberon, vasetti, bottigliette...  
 Completo di tasca per cavo e spinotto.  
 Si collega alla presa accendisigari. Maniglia trasporto.  
 Passetto in velcro per cintura. Tasca multifunzione

**BOTTLE AND BABY FOOD WARMER BAG, 12V**  
 For warming baby food anytime. Suitable for feeding bottles,  
 cans and pots. Includes: pocket for storage of cable and lighter  
 plug. Loop for belt carrier. External multipurpose pocket

**72983** 12V - 28W

Scatola / Box  4 / 20



Doppio voltaggio  
 Dual voltage



**SCALDA BIBERON 12/220V**  
 Per scaldare il pasto a casa, in viaggio ed  
 in vacanza. Con termostato per regolare la  
 temperatura desiderata

**BOTTLE AND BABYFOOD WARMER 12/220V**  
 For warming baby food anytime when on a  
 journey and on holidays

**72984** 12V-100W / 220V-120W

Scatola / Box  8 / 24



160W

**KALOR, SCALDINO / SBRINATORE  
 ELETTRICO 12V, 160 W**

Con termostato, cavo 180 cm e  
 spinotto per presa accendisigari

**KALOR, HEATER / DEFROSTER  
 12V, 160 W**  
 With thermostat

**72981** 12V - 160W

D/Blister  6 / 24



180W

**HOT-AIR, PHON ASCIUGACAPELLI  
 E SBRINATORE 12V, 180W**

Si collega alla presa accendisigari.  
 Con protezione termica. Cavo da 2,4 m.  
 Design compatto, manico ripiegabile

**HOT-AIR, HAIR-DRYER AND DEFROSTER  
 12V, 180W**  
 With thermal protection. 2,4 m power cord.  
 Plugs directly into cigarette lighter socket.  
 Foldable, compact size for easy storage

**72982** 12V - 180W

Scatola / Box  4 / 20



## Frigorifero con Compressore Compressor cool boxes

Per **REFRIGERAZIONE** o **CONGELAMENTO**.  
Temperatura di esercizio da **+10° a -18°C**.  
Regolabile tramite termostato digitale.

For **REFRIGERATION** or **FREEZING**.  
Working temperature from **+10° to -18° C**.  
Controlled by digital thermostat.



### FRIGORIFERI CON COMPRESSORE - 12/24V

- **Design compatto con eccellenti performance:** grazie all'utilizzo del nuovo compressore BD-Micro il frigorifero risulta compatto all'esterno e capiente all'interno, come un frigorifero termoelettrico.
- **Risparmio energetico:** il BD-Micro è un compressore con controllo elettronico integrato che regola i giri in base alla temperatura impostata con il termostato e a quella interna al frigorifero, i consumi sono dunque ridotti al minimo.
- **Alta qualità:** realizzato interamente ad iniezione con materiali di prima qualità.
- **Inimitabile compagno di viaggio:** il peso ridotto (solo 9 Kg) e la comoda tracolla rendono il nuovo frigorifero un prodotto perfetto per essere facilmente trasportato in ogni luogo

### COMPRESSOR COOL BOXES - 12/24V

- **Compact design and excellent performance:** thanks to the new BD Micro compressor, the TB18 is compact outside and spacious inside like a thermoelectric fridge.
- **Energy savings:** the BD Micro is a compressor with integrated control electronics which regulate the speed according to the temperature set on the thermostat and the inside of the refrigerator, consumption is thus reduced to a minimum.
- **High performance:** the cooler box is small and light like a thermoelectric fridge but extremely performing thanks to the compressor.
- **High quality:** the new cooler box is all injection made using high quality components.
- **Inimitable travel mate:** thanks to its low weight (only 9 Kg) and the adjustable shoulder strap the new compressor cooler box is particularly easy to carry and transport everywhere

<b>TB01215</b>	<b>TB15</b>	15 L	12/24V
<b>TB01218</b>	<b>TB18</b>	18 L	

Cartone / Carton ☐ 1



**15**  
L

**18**  
L

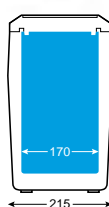
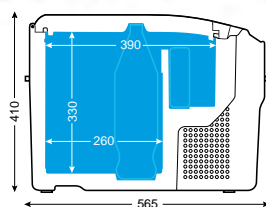
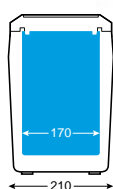
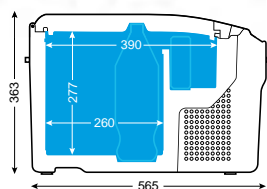

#### DATI TECNICI

- Potenza installata: **35 Watt**
- Tensione: **DC 12-24 V**
- Regolazione termostatica: **+10 a -18C**
- Compressore:  
**SECOP BD Micro (BD1.4F)**
- Gas Refrigerante: **R134a CFC FREE**

#### TECHNICAL DATA

- Installed power: **35 Watt**
- Voltage: **DC 12-24 V**
- Thermostatic regulation: **+10 to -18C**
- Compressor:  
**SECOP BD Micro (BD1.4F)**
- Refrigerant: **R134a CFC FREE**



# T-Tech 18

FRIGORIFERO +  
SCALDAVIVANDE  
**2 in 1**  
DOUBLE-FUNCTION



Display digitale temperatura e termostato  
Thermostat and digital display thermometer



Griglia separatrice  
Separating grill



12/24/230 V

18  
litri

12-24V

230V



+55°C +70°C

RISCALDAMENTO  
RAFFREDDAMENTO

-20°C -25°C\*

\*Rispetto alla temperatura ambiente  
\*Below ambient temperature

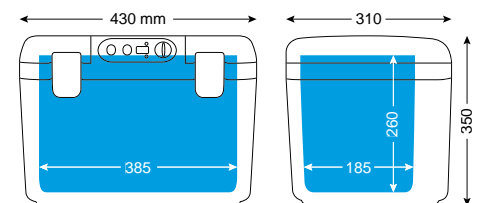

## T-TECH 18, FRIGORIFERO SCALDAVIVANDE 18 LITRI, 12/24V+230V

- Doppia funzione: raffreddamento e riscaldamento.
- Struttura in plastica anti-urto con isolamento in poliuretano CFC-free.
- Alta capacità interna (18 Litri) con un minimo ingombro esterno.
- Maniglia di trasporto e tracolla.
- Pannello con display digitale temperatura e termostato di regolazione.
- Funzione Eco/Energy Saving A++.
- Griglia separatrice.
- Due elementi termici da 4A con sistema termoelettrico (Peltier).
- Equipaggiato con motori "brushless" silenziosi e di lunga durata.
- Consumo: 12V / 24V DC 60W ± 10%, 230V AC 80W ± 10%.

## T-TECH 18, THERMOELECTRIC COOLER & WARMER, 12/24V+230V

- Two functions: cooling and warming.
- Solid polyurethane foam insulation (CFC-free).
- Capacity: 18 litres.
- Red/green lights shows hot/cold status.
- Shoulder strap and carrying handle included.
- Control panel with thermostat and digital display thermometer.
- With function Eco/Energy Saving A++.
- Maintenance-free Peltier double cooling systems.
- Equipped with long life brushless motors.
- Maximum volume with compact outside dimensions.
- Consumption: 12V / 24V DC 60W ± 10%, 230V AC 80W ± 10%.

**89052** 12/24V+230V

Scatola / Box 2

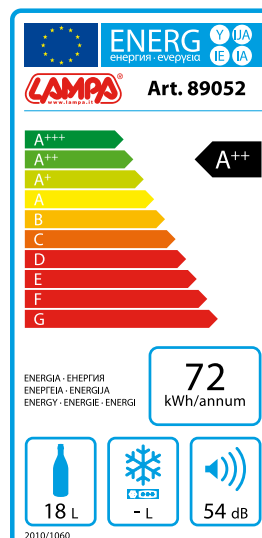



**EZETIL, FRIGORIFERO - 12V/24V+230V**

Adatto per auto (12V), camion o barca (24V) e uso domestico (230V). Ideale per campeggio, viaggi, shopping e uso professionale. Permette un risparmio energetico fino al 70% se usato a 230V (paragonato ai tradizionali frigoriferi per auto). Rispetta le normative Europee EC643/2009 (Requisiti di rendimento energetico dei frigoriferi). Risparmio energetico: A+ (Efficiency index EEI <55).

- Sistema di raffreddamento termoelettrico (Peltier) con motori brushless, esente da manutenzione
- Ventola aggiuntiva per prestazioni di raffreddamento rapide e costanti
- Protezione batteria integrata (AES) con funzione ON / OFF. Se azionato consente di evitare che il frigorifero scarichi la batteria dell'auto.
- Gomma di tenuta nel coperchio che evita la formazione di condensa
- Blocco automatico del coperchio durante il trasporto
- Struttura in plastica estremamente robusta e resistente agli urti

**Modalità 230V:**

- Regolazione automatica della temperatura.
- Funzione "Boost" per un raffreddamento rapido e costante
- Temperatura tra + 8°C e + 14°C all'interno del refrigeratore garantita, anche ad una temperatura ambiente di 32°C

**Modalità 12V o "Boost":**

- Raffredda fino a 20°C al di sotto della temperatura ambiente

**EZETIL, THERMOELECTRIC COOLER - 12V/24V+230V**

Electric cool box for car (12V), lorry or boat (24V) and home use (230V). Ideal for camping, travelling, shopping or professional use...

Energy class = A+ (no.6943/2009, energy efficiency index EEI<55), capacity according to EN 15502 = 23L, noise = 45 db

More than 70% energy saving while having a better performance

- Strong maintenance free Peltier cooling system
- Additional fan for a quick and constant cooling performance
- Integrated battery guard (AES) with an ON/OFF function
- Special sealing rubber in the lid avoids condensation
- Automatic lockage of the lid when carrying
- Extremely robust and shock resistant underpart

**230V mode:**

- Automatic regulation of the temperature
- "Boost-function" for a quick and constant cooling performance
- Temperature between +8°C et +14°C inside the cooler guaranteed, even by an ambient temperature of 32°C

**12V or "Boost" mode:**

- Cools up to 20°C below the ambient temperature

**EZ776676 23 L**

Scatola / Box 1



\*Rispetto alla temp. ambiente.  
\*Below ambient temperature

**23**  
lt

**12-24V**

**230V**

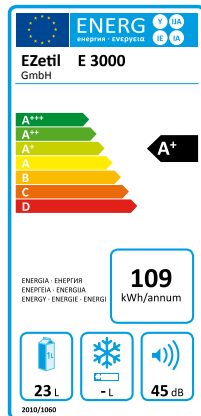

Display LCD integrato indica la temperatura all'interno in °C o °F

Integrated LCD display, indicates the temperature inside the cooler in °C or °F

**SERIE CON SISTEMA PER IL FISSAGGIO DELLE CINTURE DI SICUREZZA**

I 3 punti di fissaggio della cintura di sicurezza prevengono lo scivolamento delle stesse dal frigorifero. In questo modo lo trattengono ancorato al sedile e quindi sotto controllo. Il sistema SSBF è stato testato per l'idoneità secondo le direttive ECE R17 in una simulazione di "crash-test".

**SERIES WITH SAFE SEAT BELT FIXATION**  
3 fixing devices prevent that the safety belt slides and keep the cooler reliably fixed and under control. SSBF has been tested for practical suitability according to ECE directive R17 in a crash test situation.



Vano portaoggetti nel coperchio con porta scorrevole per i cavi 12/24V e 230V

Storage compartment in the lid with sliding door for the 12/24V and 230V cables

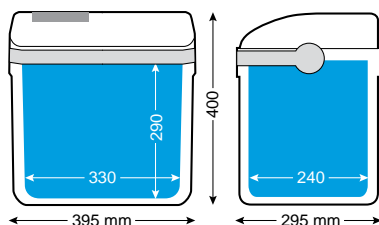

Può contenere bottiglie da 1,5 L (x6) e 2 L (x4) in posizione verticale o 34 lattine (0,33 L)

Can hold bottles of 1,5 L (x6) and 2 L (x4) in the upright position or 34 cans (0,33 L)



**NUOVA SERIE  
NEW SERIES**

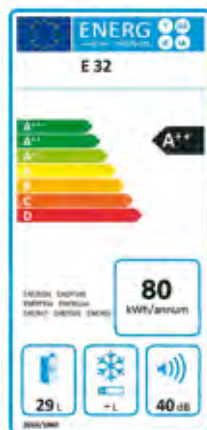

**EZETIL, FRIGORIFERO - 12V+230V**

- Sistema di raffreddamento termoelettrico (Peltier) con motori brushless. Dotato di ECO-MIN-MAX-CONTROL che permette un risparmio energetico fino al 70% se usato a 230V (paragonato ai tradizionali frigoriferi per auto). Rispetta le normative Europee EC643/2009 (Requisiti di rendimento energetico dei frigoriferi)
- Consumo: 12V - 230V
  - Risparmio energetico: A++ (Efficiency index EEI <55)
  - Raffredda fino a 17°C al di sotto della temperatura ambiente.
  - Guarnizione per ridurre la condensa.
  - È dotato di una ventola aggiuntiva per un raffreddamento immediato e costante
  - Struttura in plastica antiurto e coperchio removibile.
  - Durante il trasporto la maniglia blocca il coperchio
  - Il filo e lo spinotto possono essere alloggiati nella parte posteriore del frigorifero
  - Coperchio removibile

**EZETIL, THERMOELECTRIC COOLER - 12V+230V**

- Maintenance-free Peltier cooling system Equipped with ECO-MIN-MAX-CONTROL - allows energy savings of up to 70% if used on 230V (compared to conventional thermoelectric coolers).
- Consumption: 12V - 230V
  - Efficiency class: A++ (Efficiency index EEI <55) According regulation (EC) no.6943/2009, energy efficiency index EEI<55
  - Cools up to 17°C below ambient temperature
  - Additional interior fan for quick and constant cooling effect.
  - Rubber sealing in the lid reduces condensation
  - When carrying the cooler, the handle locks the lid.
  - Existing cable compartment on the back side of the cooler for safely repacking the equipment (12V and 230V plugs and cables).
  - Detachable lid.
  - Extra robust and impact resistant body.

**EZ776970 29 L**  
**EZ776870 24 L**

Termoretraibile / Shrink-pack ☐ 1



\*Rispetto alla temp. ambiente.  
\*Below ambient temperature



**CON TERMOSTATO  
WITH THERMOSTAT**

**NUOVA SERIE CON SISTEMA PER IL FISSAGGIO DELLE CINTURE DI SICUREZZA**  
I 3 punti di fissaggio della cintura di sicurezza prevengono lo scivolamento delle stesse dal frigorifero. In questo modo lo trattengono ancorato al sedile e quindi sotto controllo. Il sistema SSBF è stato testato per l'idoneità secondo le direttive ECE R17 in una simulazione di "crash-test".

**NEW SERIES WITH SAFE SEAT BELT FIXATION**  
3 fixing devices prevent that the safety belt slides and keep the cooler reliably fixed and under control. SSBF has been tested for practical suitability according to ECE directive R17 in a crash test situation.



**29 L** Può contenere due bottiglie da 2 litri in verticale  
Hold 2x 2 litres bottles standing upright.

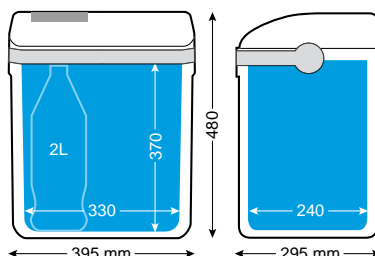

**24 L** Può contenere due bottiglie da 1,5 litri in verticale  
Hold 2x 1,5 litres bottles standing upright.

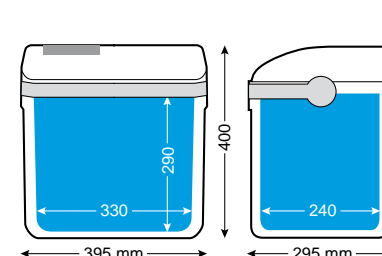



**MIRABELLE, FRIGORIFERO 22L - 12V**

Sistema di raffreddamento termoelettrico (Peltier) con motori brushless

- Consumo: 12V
- Raffredda fino a 14°C al di sotto della temperatura ambiente.
- Può contenere 1 bottiglia da 1,5L in piedi (fino a 24 lattine da 0,33L).
- Guarnizione per ridurre la condensa.
- È dotato di una ventola aggiuntiva per un raffreddamento immediato e costante
- Struttura in plastica antiurto e coperchio removibile.
- Il filo e lo spinotto possono essere alloggiati nel coperchio

**MIRABELLE, THERMOELECTRIC COOLER 22L - 12V**

Maintenance-free Peltier cooling system

- Consumption: 12V
- Cools up to 14°C below ambient temperature
- Holds 1,5 litre Euro bottles standing upright (24 cans x 033L).
- Additional interior fan for quick and constant cooling effect.
- Rubber sealing in the lid reduces condensation
- When carrying the cooler, the handle locks the lid.
- 12V plug and cable can be stored in a special compartment with sliding door.
- Extra robust and impact resistant body.

**EZ770610 22 L**

Termoretraibile / Shrink-pack 1



\*Rispetto alla temp. ambiente.  
\*Below ambient temperature

**22 L**



**12V UNIVERSAL**



**22 L**

Può contenere una bottiglia da 1,5 litri in verticale  
Hold 1x 1,5 litres bottles standing upright.

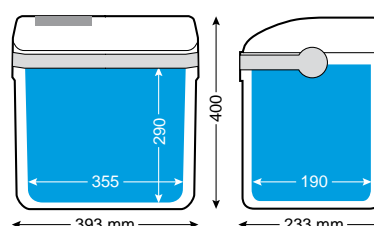



Torcia supplementare  
Extra torch



GL-1



**GL-1, LAMPADA ISPEZIONE A LED CON TORCIA**

- Con piedistallo magnetico, reclinabile.
- In plastica antiurto, con gancio.
- Ottima illuminazione.
- Basso consumo di energia.
- Lunga durata

**GL-1, LED INSPECTION LIGHT WITH TORCH**

- With swivel magnetic stand.
- Shockproof plastic and hook.
- High lighting.
- Low power consumption.
- Long-lasting

<b>70638</b>	1 pz	D/Blister	10 / 40
<b>70639</b>	1 pz	Sfuso / Bulk	12 / 48
<b>70639D</b>	Display 12 pz	Scatola / Box	1



Display  
12 pcs



4+3 LED  
192 lm

7000°K

Batterie (non incluse)	3 x AAA	Battery (not included)
Durata batteria	± 6 h	Work time
Fonte luminosa	2W SMD + 0,2W Led	Light source
Luminosità	180 + 12 lm	Luminance
Temperature luce	7000° K	Colour Temperature
Classe di protezione	IP 20	Protection class



GL-2

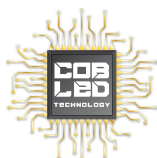

**GL-2, LAMPADA ISPEZIONE RICARICABILE A LED COB**

- Con piedistallo magnetico, reclinabile.
- Ricaricabile tramite cavo USB con trasformatore 230V o spinotto 12/24V (in dotazione)
- In gomma e policarbonato.
- Doppio sistema di fissaggio: tramite gancio e magnete.
- Basso consumo di energia, lunga durata.

**GL-2, RECHARGEABLE COB LED INSPECTION LIGHT**

- With swivel magnetic stand.
- Rechargeable via USB cable with 230V transformer or 12/24V plug (included)
- Shockproof, rubber and polycarbonate.
- Double fixing system: with hook and magnetic.
- Low power consumption, long-lasting.

<b>70640</b>	D/Blister	10 / 20
--------------	-----------	---------



1 LED  
150 lm

7000°K

Batteria	Li-ion 3,7V - 1800 mA	Battery
Tempo di ricarica	± 5 h	Charging time
Durata batteria	3 h	Work time
Fonte luminosa	2W COB LED	Light source
Luminosità	150 lm	Luminance
Temperature luce	7000° K	Colour temperature
Alimentazione caricabatteria	110-240V AC	Home charger
Alimentazione veicolare	USB 12/24V DC	Car charger
Classe di protezione	IP20	Protection class



GL-3

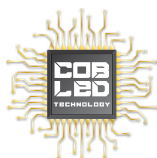

Torcia supplementare  
Extra torch



**GL-3, LAMPADA DA LAVORO RICARICABILE A LED COB CON TORCIA**

- Con base snodabile magnetica.
- Ricaricabile tramite cavo USB con trasformatore 230V o spinotto 12/24V (in dotazione)
- In plastica antiurto, lente in policarbonato, con due magneti e due ganci di fissaggio.
- Basso consumo di energia.
- Lunga durata.

**GL-3, RECHARGEABLE COB LED WORKING LIGHT WITH TORCH**

- With swivel magnetic base.
- Rechargeable via USB cable with 230V transformer or 12/24V plug (included)
- Shockproof plastic, polycarbonate lens, with 2 back magnets and 2 hooks.
- Low power consumption.
- Long-lasting.

**70641**

Scatola / Box ☐ 10



Batteria	Li-ion 3,7V - 2200 mA	Battery
Tempo di ricarica	± 5 h	Charging time
Durata batteria	3 h	Work time
Fonte luminosa	1W LED + 4W COB LED	Light source
Luminosità	80 + 250 lm	Luminance
Temperature luce	7000° K	Colour temperature
Alimentazione caricabatteria	110-240V AC	Home charger
Alimentazione veicolare	USB 12/24V DC	Car charger
Classe di protezione	IP20	Protection class



Torcia supplementare  
Extra torch



GL-4 **SMD TECHNOLOGY**

**GL-4, LAMPADA DA LAVORO RICARICABILE A LED CON TORCIA**

- Ricaricabile tramite cavo USB con trasformatore 230V o spinotto 12/24V (in dotazione)
- In plastica antiurto, lente in policarbonato, con magnete e gancio di fissaggio.
- Basso consumo di energia, lunga durata.

**GL-4, RECHARGEABLE LED WORKING LIGHT WITH TORCH**

- Rechargeable via USB cable with 230V transformer or 12/24V plug (included)
- Shockproof plastic, polycarbonate lens, with magnet and hook.
- Low power consumption, long-lasting.

**70642**

Scatola / Box ☐ 20



Batteria	Li-ion 3,7V - 4400 mA	Battery
Tempo di ricarica	± 6 h	Charging time
Durata batteria	± 4 h	Work time
Fonte luminosa	6W SMD LED (1x1W + 10x0,5W)	Light source
Luminosità	560 lm	Luminance
Temperatura luce	7000° K	Colour Temperature
Alimentazione caricabatteria	110-240V AC	Home Charger
Alimentazione veicolare	USB 12/24V DC	Car Charger
Classe di protezione	IP 54	Protection class



GL-6

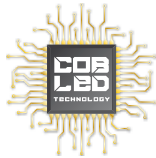

**GL-6, LAMPADA ISPEZIONE RICARICABILE A LED COB**

- Con proiettore reclinabile e rotante.
- Ricaricabile tramite cavo USB con trasformatore 230V o spinotto 12/24V (in dotazione)
- In plastica antiurto, lente in policarbonato, con magnete posteriore e gancio di fissaggio.
- Basso consumo di energia, Lunga durata.

**GL-6, RECHARGEABLE COB LED INSPECTION LIGHT**

- With swiveling projector.
- Rechargeable via USB cable with 230V transformer or 12/24V plug (included)
- Shockproof plastic, polycarbonate lens, with magnet and hook.
- Low power consumption, Long-lasting.

**70644**

Scatola / Box 20



**LED** **230V** **12-24V** **1 LED 250 lm** **7000°K**

Batteria	Li-Ion 3,7V - 2200 mA	Battery
Tempo di ricarica	± 5 h	Charging time
Durata batteria	3 h	Work time
Fonte luminosa	4W COB LED	Light source
Luminosità	250 lm	Luminance
Temperature luce	7000° K	Colour temperature
Alimentazione caricabatteria	110-240V AC	Home charger
Alimentazione veicolare	USB 12/24V DC	Car charger
Classe di protezione	IP20	Protection class



GL-7

DUE potenze - DUAL power

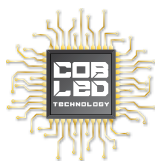
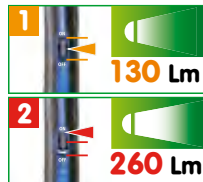

Con base di ricarica  
With rechargeable base

**GL-7, LAMPADA DA LAVORO RICARICABILE A LED COB**

- Ricaricabile tramite cavo USB con trasformatore 230V o spinotto 12/24V (in dotazione)
- Con base per ricarica.
- In plastica antiurto, lente in policarbonato, con magnete e gancio.
- Basso consumo di energia, lunga durata.

**GL-7, RECHARGEABLE COB LED WORKING LIGHT**

- Rechargeable via USB cable with 230V transformer or 12/24V plug (included)
- With charging base.
- Shockproof plastic, polycarbonate lens, with magnet and hook.
- Low power consumption, long-lasting.

**70645**

Scatola / Box 10



**LED** **230V** **12-24V** **1 LED 260 lm** **7000°K**

Batteria	Li-ion 3,7V - 2200 mA	Battery
Tempo di ricarica	± 5 h	Charging time
Durata batteria	130 lm ± 5,5 h 260 lm ± 3 h	Work time
Fonte luminosa	4W COB LED	Light source
Luminosità	130 / 260 lm	Luminance
Temperature luce	7000° K	Colour Temperature
Alimentazione caricabatteria	110-240V	Home Charger
Alimentazione veicolare	USB 12/24V	Car Charger
Classe di protezione	IP20	Protection class



GL-8



SMD TECHNOLOGY



**GL-8, LAMPADA DA LAVORO A LED**

- In plastica antiurto, lente in policarbonato, con magnete e gancio.
- Basso consumo di energia.
- Lunga durata.

**GL-8, LED WORKING LIGHT**

- Shockproof plastic, polycarbonate lens, with magnet and hook.
- Low power consumption.
- Long-lasting.

**70646**

D/Blister 20



**4 LED  
180 lm**

**7000°K**

Batterie (non include)	<b>3 x AA</b>	Battery (not included)
Durata batteria	<b>± 6 h</b>	Work time
Fonte luminosa	<b>2W SMD LED</b>	Light source
Luminosità	<b>180 Lm</b>	Luminance
Temperature luce	<b>7000° K</b>	Colour Temperature
Classe di protezione	<b>IP 20</b>	Protection class



Pro-Lamp

SMD TECHNOLOGY



**PRO-LAMP, COMPACT ULTRABRIGHT, LAMPADA DA LAVORO A LED SMD**

- Ricaricabile tramite cavo USB con trasformatore 230V (in dotazione)
- Con base per ricarica.
- In plastica antiurto, lente in policarbonato, con magnete e gancio di fissaggio.
- Ottima illuminazione.
- Basso consumo di energia, lunga durata.

**GL-4, COMPACT ULTRABRIGHT, SMD LED WORKING LIGHT**

- Rechargeable via USB cable with 230V transformer (included)
- With charging base.
- Shockproof plastic, polycarbonate lens, with magnet and hook.
- High lighting.
- Low power consumption, long-lasting.

**70648**

Scatola / Box 10 / 40



**8 LED  
260 lm**

**6000°K**

Batteria	<b>3.7V 2200mA Li-ion</b>	Rechargeable Battery
Tempo di ricarica	<b>± 3,5 ore/hours</b>	Charging time
Durata batteria	<b>± 5 ore/hours</b>	Work time
Fonte luminosa	<b>4W (8x0,5w) SMD LED</b>	Light source
Luminosità	<b>260 lm</b>	Luminance
Temperatura luce	<b>6000° K</b>	Colour Temperature
Alimentazione caricabatteria	<b>110V-240V</b>	Home Charger
Alimentazione veicolare	<b>USB 2.0 - 5V</b>	Car Charger
Classe di protezione	<b>IP 66</b>	Protection class

Con base di ricarica  
With rechargeable base







**Manico in gomma  
Rubber handle**

**Ricaricabile  
Rechargeable**



## GL-5

### GL-5, LAMPADA DA LAVORO RICARICABILE A LED COB

- Ricaricabile tramite cavo USB con trasformatore 230V o spinotto 12/24V (in dotazione)
- In gomma antiurto e policarbonato.
- Portalampana con base magnetica e gancio.
- Basso consumo di energia, lunga durata.

### GL-5, RECHARGEABLE COB LED WORKING LIGHT

- Rechargeable via USB cable with 230V transformer or 12/24V plug (included)
- Shockproof rubber and polycarbonate.
- With magnet and hook.
- Low power consumption, long-lasting.

**70643**

D/Blister 10



**LED** **230V** **12-24V** **1 LED 200 lm** **7000°K**

Batteria	Li-Ion 3,7V 2200 mA	Battery
Tempo di ricarica	± 5 h	Charging time
Durata batteria	± 3 h	Work time
Fonte luminosa	3W COB LED	Light source
Luminosità	200 lm	Luminance
Temperatura luce	7000° K	Colour Temperature
Alimentazione caricabatteria	110-240V AC	Home Charger
Alimentazione veicolare	USB 12/24V DC	Car Charger
Classe di protezione	IP20	Protection class



**500 cm  
Cavo - Cable**

## GL-9

### GL-9, LAMPADA DA OFFICINA A LED COB, 230V

- In gomma e policarbonato.
- Alta resistenza agli urti.
- Con gancio girevole.
- Basso consumo di energia.
- Lunga durata.

### GL-9, COB LED WORKING LIGHT, 230V

- Highly Shock resistant
- Rubber coated handle and swivel hanging hook.
- Low power consumption.
- Long-lasting

**70647**

Scatola / Box 10



**LED** **230V** **1 LED 650 lm** **7000°K**

Alimentazione	230V AC	Power supply
Cavo	5 m	Cable
Light source	10W COB LED	Light source
Vita Led	50.000 h	Led life time
Luminosità	650 lm	Luminance
Temperature luce	7000° K	Color temperature
Classe di protezione	IP54	Protection Class
Materiale	Rubber / PC / Nylon / ABS	Material
Altezza totale (gancio incluso)	46 cm	Length including hook

# Cob-Led Multi Power

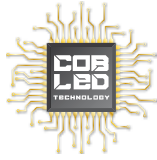

### COB-LED MULTI POWER, LAMPADA DA MANUTENZIONE A LED COB

- Corpo luminoso ad alta luminescenza.
- Kit veicolare per collegamento alla presa accendisigari dell'auto (12V) o camion (24V) con cavo da 320 cm.
- Kit portatile con "battery pack" per 6 pile AA (non in dotazione).
- Supporto magnetico e gancio girevole

### COB-LED MULTI POWER, MAINTENANCE LIGHT

- High brightness projector light.
- Vehicle connection with cigarette lighter plug for car (12V) and truck use (24V).
- Portable battery pack for 6xAA drycell batteries (not included).
- Magnetic stand and swivel hanging hook

**70657**

D/Blister 12



**Battery Pack per 6 pile AA**  
Battery Pack for 6xAA batteries



**12/24V**

**Spinotto accendisigari**  
Cigarette lighter plug



**Gancio**  
Hang



**Piedistallo magnetico**  
Magnetic stand

**320 cm**  
Cavo - Cable

**LED**

**12-24V**  
UNIVERSAL

**6**  
AA

**1 LED**  
500 lm

**7000°K**

Doppia Alimentazione	<b>12/24V (6xAA)</b>	Twin Power supply
Cavo	<b>320 cm</b>	Cable
Light source	<b>3,6W COB LED</b>	Light source
Luminosità	<b>500 lm</b>	Luminance
Temperature luce	<b>7000° K</b>	Color temperature
Materiale	<b>ABS</b>	Material
Altezza totale (gancio incluso)	<b>43 cm</b>	Length including hook





# GL-11 Trucker 5w

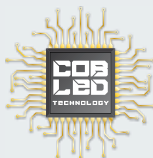

### GL-11 TRUCKER, LAMPADA ISPEZIONE RICARICABILE A LED COB

- In plastica antiurto, con magnete posteriore e gancio di fissaggio.
- Ricaricabile tramite spinotto accendisigari 12/24V (in dotazione). Ottima illuminazione. Basso consumo di energia. Lunga durata.

### GL-11 TRUCKER, RECHARGEABLE COB LED INSPECTION LIGHT

- Shockproof plastic, with rear magnet and hook.
- Rechargeable with 12/24V cigarette lighter plug (included). High lighting. Low power consumption.
- Long-lasting.

**70649**

Scatola / Box 6 / 24

LED

12-24V

USB

2 LED  
380 lm

7000°K

Batteria	<b>Lead-Acid - 6 V - 1200 mA</b>	Battery
Tempo di ricarica	<b>± 3 h</b>	Charging time
Durata batteria	<b>5 h</b>	Work time
Fonte luminosa	<b>5 W COB LED</b>	Light source
Luminosità	<b>360 / 380 lm</b>	Luminance
Temperature luce	<b>7000° K</b>	Colour temperature
Alimentazione veicolare	<b>12 / 24 V DC</b>	Car charger
Classe di protezione	<b>IP44</b>	Protection class



Presse USB per ricarica cellulari  
USB charger for cell phone charging

Presse per alimentatore accendisigari  
Power supply lighter socket

Gancio per appendere  
Hook to hang

Retro con magnete  
Magnet at the back



# GL-10 1w

LED

3 AAA

IP 44

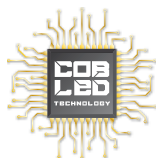

2 LED  
100 lm

6000°K



### GL-10, LAMPADA ISPEZIONE A LED CON TORCIA

- Con clip magnetica girevole.
- Ottima illuminazione.
- Basso consumo di energia.
- Lunga durata

### GL-10, LED INSPECTION LIGHT WITH TORCH

- With revolving magnetic clip.
- High lighting.
- Low power consumption.
- Long-lasting

<b>70637</b>	1 pz	D/Bister 12 / 48
<b>70637D</b>	Display 12 pz	Scatola / Box 1



Torcia supplementare  
Extra Torch



Display  
12 pcs

Batterie (non include)	<b>3 x AAA</b>	Battery (not included)
Durata batteria	<b>± 6 h</b>	Work time
Fonte luminosa	<b>1W Cob + 1 Led</b>	Light source
Luminosità	<b>100 lm</b>	Luminance
Temperature luce	<b>6000° K</b>	Colour Temperature
Classe di protezione	<b>IP 44</b>	Protection class

## Trix 3w

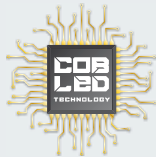

7000°K

1 LED  
180 lm

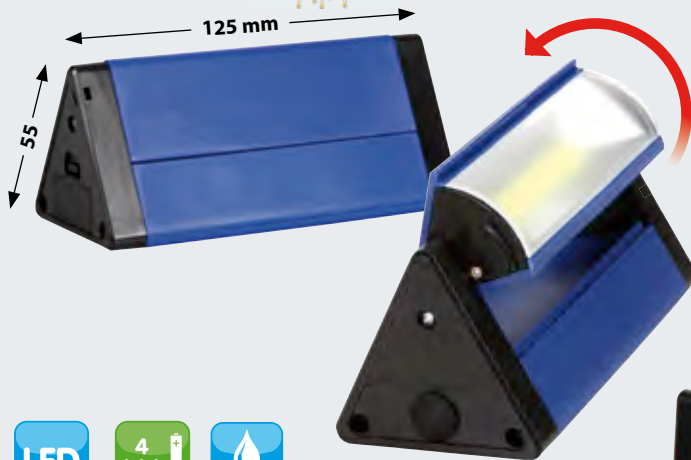

IPX3

### TRIX, LAMPADA ISPEZIONE A LED ORIENTABILE

- In plastica antiurto.
- Base magnetica.
- Fascio luce orientabile a scomparsa.
- Selettore luminosità: 50% (90 lm) e 100% (180 lm)

### TRIX, LED INSPECTION LIGHT

- Shockproof plastic.
- Magnetic base.
- Adjustable angle beam.
- Brightness switch: 50% (90 lm) and 100% (180 lm)

**70635**

D/Blister 12 / 48

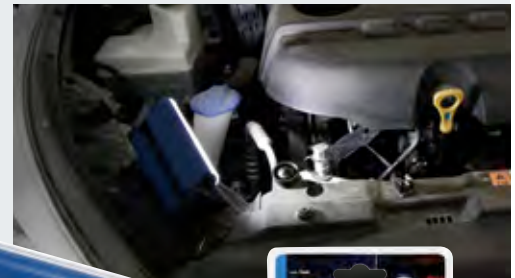

Batterie (non incluse)	4 x AAA	Battery (not included)
Durata batteria	± 4 h	Work time
Fonte luminosa	3W Cob	Light source
Luminosità max	180 lm	Max luminance
Temperature luce	7000° K	Colour Temperature
Classe di protezione	IPX3	Protection class
Dimensioni	125x50x55 mm	Dimensions

## Hook-Lite 3w

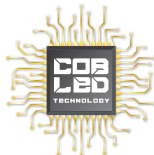

5 LED  
180 lm

7000°K



IPX3

### HOOK-LITE, LAMPADA A LED MULTIFUNZIONE

- In plastica antiurto, con pratico gancio.
- 5 funzioni: luce a alta e bassa intensità, luce rossa fissa e intermittente, torcia a Led

### HOOK-LITE, MULTIFUNCTION LED LIGHT

- Shockproof plastic with useful hook.
- 5 functions: low/high intensity light, steady/flashing red light, led torch

**70636**

D/Blister 12 / 48



**5 Funzioni**  
Functions



Lampada Cob  
High intensity

Lampada Cob  
Low intensity

Luce rossa  
Red light

Luce rossa  
intermittenza  
Intermittence red light

Torcia a led  
Led torch

Batterie (non incluse)	4 x AAA	Battery (not included)
Durata batteria	± 4 h	Work time
Fonte luminosa	3W Cob + 4 Led	Light source
Luminosità max	180 lm	Max luminance
Temperature luce	7000° K	Colour Temperature
Classe di protezione	IPX3	Protection class
Dimensioni	40x25x150 mm	Dimensions

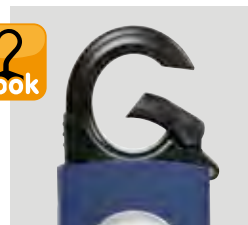



**PATROL-LED, TORCIA A LED IN ALLUMINIO**  
 Torcia in alluminio anodizzato. Equipaggiata con LED "CREE"® di ultima generazione. Lunga durata, altissima intensità luminosa e basso consumo. Progettata secondo specifiche militari e forgiata dal pieno tramite l'ultima tecnica di lavorazione "CNC" (Computer Numeric Control). Batterie non incluse

**PATROL-LED, ALUMINIUM LED TORCH**  
 Ultra brightness aluminium torch. Ultimate performance led technology. Long life, high brightness intensity and low battery consumption. Engineered according to military specifications. Waterproof. Batteries not included



# Patrol-Led

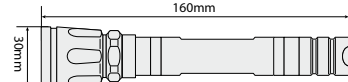
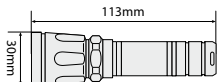
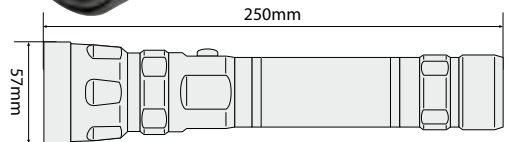

**72026 Compact - 1W**

D/Blister 10 / 100

**72025 Slim - 1W**

D/Blister 10 / 100

**72027 Maxi - 3W**

D/Blister 10 / 40

**RANGER-LED, TORCIA RICARICABILE A LED**  
 Torcia in alluminio anodizzato con Led CREE® Q3 di ultima generazione. Altissima intensità luminosa e basso consumo. Progettata secondo specifiche militari e forgiata dal pieno tramite tecnica CNC (Computer Numeric Control). Batterie Ni-MH ricaricabili incluse

**RANGER LED TORCH**  
 Ultra brightness aluminium torch, ultimate performance led technology. Waterproof. Long life, high brightness intensity and low battery consumption. Engineered according to military specifications. Ni-MH rechargeable battery pack included

- Professional kit, comprende:
- Pack Batterie Ni-MH ricaricabili
  - Trasformatore per ricarica da presa domestica 230V
  - Spinotto presa accendisigari per ricarica veicolare 12V
- Professional kit includes:
- Ni-MH rechargeable battery pack
  - Adaptor for 230V domestic sockets
  - Cigarette lighter plug for 12V vehicles (car, motorhome, van...)

**72029 Maxi - 5000 mAh**

Scatola / Box 5 / 10



# Ranger-Led Professional Kit

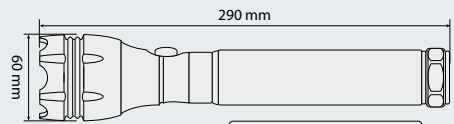

**5000 mAh**

# Touring



Colori Assortiti  
Assorted Colours



9 LED  
1200 MCD

Display  
18 pcs

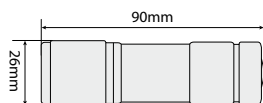

Include  
3 AAA  
Included



## TOURING, TORCIA A LED

In alluminio anodizzato. Basso assorbimento di corrente. Progettata secondo specifiche militari e forgiata CNC dal pieno. Ottima per uso civile, per l'utilizzo in auto, casa oppure all'aria aperta. Batterie incluse

## TOURING, ALUMINIUM LED TORCH

Engineered according to military specifications, excellent for civilian use at home, in the open air and the car. Batteries included

<b>72022</b>	1 pz	Sfuso / Bulk	18 / 72
<b>72022D</b>	Display 18 pz	Scatola / Box	1 / 2



# Traveller



Colori Assortiti  
Assorted Colours



1 LED SMD  
0,5 W

Display  
18 pcs

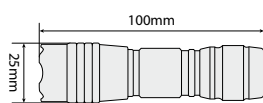

Inclusa  
1 AA  
Included



## TRAVELLER, TORCIA A LED

In alluminio anodizzato. Basso assorbimento di corrente. Progettata secondo specifiche militari e forgiata CNC dal pieno. Ottima per uso civile, per l'utilizzo in auto, casa oppure all'aria aperta.

## TRAVELLER, ALUMINIUM TORCH

Engineered according to military specifications, excellent for civilian use at home, in the open air and the car.

<b>72023</b>	1 pz	Sfuso / Bulk	18 / 72
<b>72023D</b>	Display 18 pz	Scatola / Box	1 / 4



# Led-Tech



LED  
3 AAA

9 LED



## LED-TECH, TORCIA IN ALLUMINIO 9 LED

Torcia in alluminio anodizzato equipaggiata con 9 LED ultrabianchi. Lunga durata, antiurto e basso consumo. Impermeabile. Batterie non incluse

## LED-TECH, 9 LED ALUMINIUM TORCH

Ultra brightness aluminium torch, ultimate performance led technology. Waterproof. Long life, Impact resistant and low battery consumption. Batteries not included

<b>72034</b>	138x31 mm
--------------	-----------

D/Blister 10 / 100



**TA-1 RANGER, MICROTORCIA IN ALLUMINIO**  
Impermeabile, antiurto.  
Lampadina superluminosa Krypton.  
Focalizzatore del fascio luminoso.  
Impugnatura con zigrinatura anti-scivolo. Batterie non incluse.

**TA-1 RANGER, ALUMINIUM TORCH**  
Waterproof and impact-resistant.  
Batteries not included

<b>72051</b>	Alluminio	Aluminium
<b>72052</b>	Nero	Black

D/Blister  5 / 100



**TORCIA IN GOMMA**  
Impermeabile, antiurto, lampadina krypton.  
Batterie non incluse

**RUBBER TORCH**  
Waterproof, impact resistant, with krypton bulb.  
Batteries not included

**73040** mm 190

D/Blister  10 / 40



## Pocket-Led

1w



Ricaricab./ Recharg.



**POCKET-LED, TORCIA RICARICABILE IN ALLUMINIO ANODIZZATO, 12V**

Con tecnologia Led a basso consumo energetico.  
Ricaricabile tramite spinotto accendisigari 12V.

**POCKET-LED, RECHARGEABLE ALUMINIUM TORCH, 12V**

With Led technology.  
Rechargeable through cigarette-lighter socket

**72075**

D/Blister  10 / 100



Magnetica

**LAMPADA MAGNETICA 12V**

Con avvolgicavo, spinotto accendisigari, cavo 3,6 m

**AUTO MAGNETIC LITE 12V**  
Cigarette lighter plug, 3,6 m cable with cablewinder

**72070**

D/Blister  12 / 72





**TOUCH, LAMPADA FLESSIBILE 12/24V**

15 SMD bianchi. 2 intensità di luce (bassa e alta).  
Spinotto accendisigari universale (Standard+DIN)

**TOUCH, FLEXIBLE LAMP 12/24V**  
15 white SMD. 2 light strength (low - high).  
Universal plug (Standard+DIN)

**71989** 33 cm

D/Blister 10 / 100

**TOUCH: Luce notturna e luce intera**  
**TOUCH: Dimmed light and full power**



**LAMPADA NAVIGATORE 12V**

Con cavetto a spirale. Fornita con base portalampada adesiva

**NAVIGATOR MAPLIGHT 12V**  
Spiral cable, supplied with adhesive stand

**72060** 40 cm

Blister 12 / 120



**RALLY, LAMPADA FLESSIBILE 12V**

Braccio da 25 cm, con interruttore

**RALLY 12V FLEXIBLE LAMP WITH SWITCH**  
25 cm long arm

**71990** 25 cm

Blister 12 / 96



**MONTECARLO, LAMPADA FLESSIBILE 12V**

Braccio da 48 cm

**MONTECARLO 12V**  
Flexible navigator light 12V, bulb included.  
48 cm long arm

**71995** 48 cm

D/Blister 5 / 40





**SET**



**Flessibile**  
Flexible

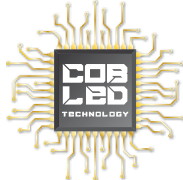

**12-24V** **1000 mA max** **5V USB**

**2 IN 1 CARICATORE USB + LAMPADA FLESSIBILE A LED COB**  
Colore nero

**2 IN 1 USB CHARGER + COB-LED FLEXIBLE LIGHT**  
Black colour

<b>71988</b>	1 pz	D/Bister	12 / 72
<b>71988D</b>	Display 12 pz	Scatola / Box	1



**Display**  
12 pcs

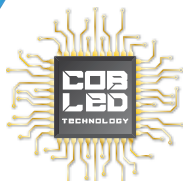

**LAMPADA FLESSIBILE A LED COB, 5V**  
Colori assortiti

**COB-LED FLEXIBLE LIGHT, 5V**  
Assorted colours

<b>71987</b>	1 pz	Sfuso / Bulk	20 / 500
<b>71987D</b>	Display 20 pz	Scatola / Box	1

**Colori Assortiti**  
Assorted Colours



**20**  
pcs

**Flessibile**  
Flexible

**5V**  
USB



**BUGGY, MICRATORCIA ADESIVA**  
Si applica al cellulare, al portachiavi, al telecomando... I due led emettono un fascio luce bianchissimo. Batterie di lunga durata incluse

**BUGGY, ADHESIVE MICRO-TORCH**  
Ultra white and high brightness twin-led. Long lasting batteries included

**72074**

D/Blister 10 / 50



**+** **LED**

**12V**  
**LED**

**Magnetica**



**LED-EYE 12V**  
Microlampada ricaricabile tramite spinotto accendisigari. Led bianco ad alta luminescenza. Con magnete per l'applicazione su superfici metalliche

**LED-EYE 12V**  
Ultra-bright white led. Rechargeable through cigarette lighter socket. Magnetic, with key-fob

**72073**

D/Blister 10 / 100

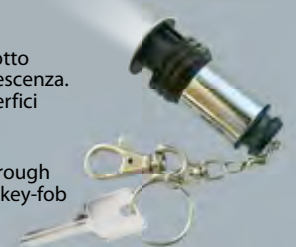



**LUCE SUPPLEMENTARE 12V**  
Base adesiva, con interruttore  
**ADHESIVE UTILITY LIGHT, 12V**  
With switch

**70661** 80x30x25 mm

Blister 12 / 288



**LUMMINA, LAMPADA ALOGENA PER INTERNI, 12V-10W**  
Universale per i veicoli a 12V. Funziona con proiezione luce verso l'alto, verso il basso, oppure in verticale con luce verso destra o verso sinistra.

**LUMMINA, HALOGEN INTERIOR LAMP, 12V-10W**  
Universal, for all 12V vehicles. Works with projector light towards the top or bottom position, or in vertical with light

**72013** 240x85 mm

Scatola / Box 5 / 30



**LUCE DI CORTESIA 12V**  
Fissaggio con viti (in dotazione), con interruttore

**12V COURTESY LIGHT**  
With switch, supplied with fitting screws

**70665** 115x40x25 mm

Blister 12 / 120



**PUSH ON LIGHT, LUCE CORTESIA UNIVERSALE**  
5 Led ultrabianchi a bassissimo assorbimento di corrente (3xAAA incluse). Base adesiva. Prodotta in abs antiurto. Ideale per casa, auto, camion, imbarcazioni, camper, roulotte...

**PUSH ON LIGHT, COURTESY-LIGHT**  
5 ultrawhite Led, extra-long working time. Energy-saving; double-side adhesive tape; high-impact abs housing. Battery-operated (3xAAA included). Push on-off switch

**70663** 160x45x22 mm

D/Blister 12 / 144



**PIVOT-4, LUCE DI CORTESIA A 4 LED, 12/24V**  
Luca bianca ultra-luminosa, grazie ai 4 led da 2000 mcd. Fulcro rotante a 180°. Con interruttore. Pre-cablata, pronta per il montaggio. Omologata E11

**PIVOT-4, INTERIOR 4 LED LIGHT, 12/24V**  
White light, 4 super-bright leds (2000 mcd). 180° swivel function. Pre-Wired, ready for fitment. With switch. E11 approved

**70666** 170 mm

Blister 25 / 100

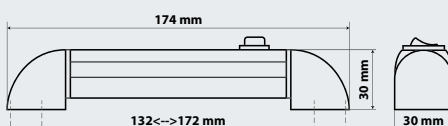

**Con lenti colorate**  
**With coloured lenses**

**LUCE CORTESIA UNIVERSALE**  
In ABS antiurto con 4 Led bianchi. Funzionamento a batteria. Base adesiva. Interruttore a pressione

**COURTESY-LIGHT ULTRA BRIGHT, WHITE LED**  
Double-side adhesive tape. High-impact ABS housing. Battery-Operated

**70662** 87x70x22 mm

Blister 12 / 192



# Neo 1



8W



## NEO-1, LAMPADA A NEON FLUORESCENTE, 12V

Pre-cablata e pronta per il montaggio. Ideale per tutti i veicoli a 12V. Con interruttore  
**NEO-1, FLUORESCENT INTERIOR LAMP, 12V**  
 Ideal for 12V vehicles. Pre-wired. On/off switch

**70667** 410x65 mm

D/Blister 10 / 20



# Lum 1



12 LED  
840 lm

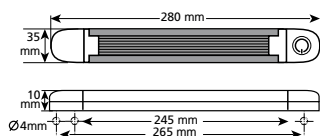

## LUM-1, LAMPADA A LED, 9/33V

12 Led, Precablata e pronta per il montaggio. Struttura in alluminio, ultra leggera. Con interruttore. Viti di fissaggio incluse.

## LUM-1, LED LAMP, 9/33V

Pre-wired, easy to fit. On/off switch. Light weight durable aluminium housing. Fixing screws included.

**70670** 280x33x10 mm

D/Blister 10 / 30

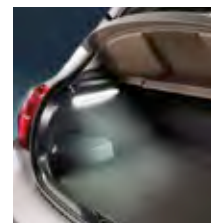

# Compact



13W



## COMPACT, LAMPADA FLUORESCENTE, 12V

Pre-cablata e pronta per il montaggio. Con interruttore a 3 funzioni:  
 Acceso • Spento • Luce cortesia "porta aperta"  
**COMPACT, FLUORESCENT INTERIOR LAMP, 12V**  
 Ideal for cars, vans, boats, motorhomes and any 12V vehicles. With 3 functions: • On • Off • Door open

**70664** 254x59 mm

D/Blister 6 / 24



# Alumina 2



IMPERMEABILE  
WATERPROOF  
IP67

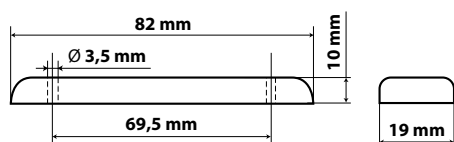

## ALUMINA-2, STRIP LUMINOSA A 2 LED, 12V

Struttura in lega di alluminio. Luce bianca, con 2 Leds da 0,6W. Pre-cablata, pronta per il montaggio. Viti per il fissaggio incluse

## ALUMINA-2, STRIP-LIGHT WITH 2 LED, 12V

White light, 2 leds (0,6W). Pre-Wired, ready for fitment. Fixing screws included

**70669** 82 mm

D/Blister 25 / 100



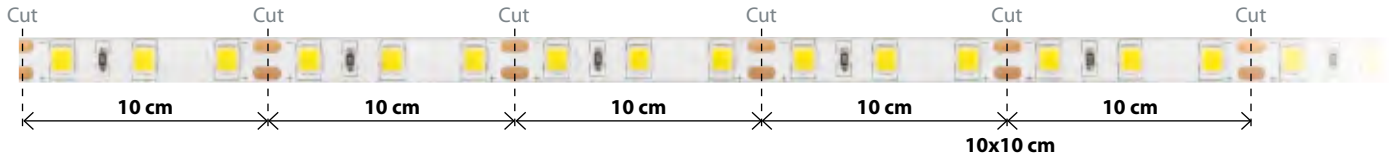

**STRISCIE A LED PER INTERNO VEICOLI, LUCE BIANCA, 12V**

- Autoadesive, flessibili, facili da installare, senza viti.
- Possibilità di accorciare, tagliare e sezionare ogni 5 cm (3 Led). Ogni sezione da 3 Led può essere a sua volta utilizzata collegando l'alimentazione 12V ai contatti sul circuito stampato.
- Alta luminosità.
- Il kit comprende 4 connettori rubacorrente e 2 salviette



**INTERIOR LED-STRIPS, WHITE LIGHT, 12V**

- Adhesive, flexible, easy to install, without any screws or drilling.
- May be shortened or cut in sections of minimum 5 cm (3 Led). Each part or section may be used and connected to 12V power supply by connecting a small wire to the contacts on the circuit board, as shown.
- High brightness.
- Kit includes 4 quick connectors and 2 wipes



**73644** 2x 150cm 90 Led

Scatola / Box 5 / 50

**LUCE BIANCA / WHITE LIGHT**

**MULTIUSO / MULTI USE**

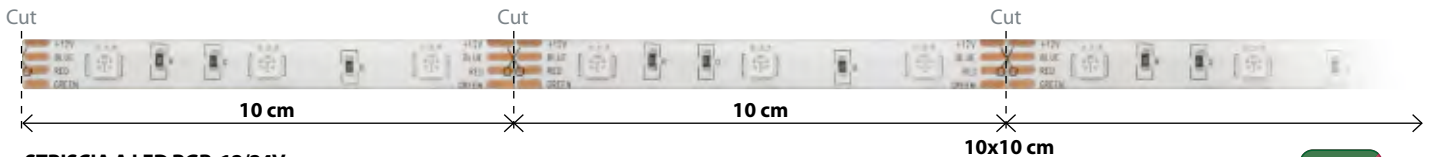

**STRISCIA A LED RGB, 12/24V**

- Multicolore 16 colori selezionabili.
- Multifunzione 4 differenti tipologie di luce.
- Regolazione dell'intensità della luce.
- Telecomando ad infrarossi incluso.
- Adesivo 3M



**RGB COLORED LED STRIP, 12/24V**

- Multicolor, 16 selectable colors.
- Multifunction, 4 different light pattern.
- Dimmer function.
- Infrared remote control.
- 3M adhesive

**73627** 200 cm 60 Led

D/Blister 6 / 24

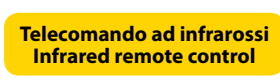

**16** Colori selezionabili  
Selectable colours

**4** Funzioni  
Functions

Regolazione intensità luce  
Dimmer function

Usa Esterno/Interno  
Indoor / Outdoor Use



# Led Set

**12x3 LED**

**SMD**  
TECHNOLOGY



**HYPER-LED SET 12x3,  
STRISCE DECORATIVE A LED - 12V**

Per illuminazione interna o esterna. Doppio sistema di fissaggio: tramite adesivo speciale o con viti non incluse. Impermeabile

**HYPER-LED SET 12x3,  
LED DECORATION LIGHT - 12V**

For internal or external use. Double fixing system: with special adhesive or screws. Waterproof

<b>73502</b>		Rosso	Red
<b>73503</b>		Blu	Blue
<b>73504</b>		Bianco	White

D/Blister  5 / 20



# Led Set

**5 x 3 LED**

**SMD**  
TECHNOLOGY

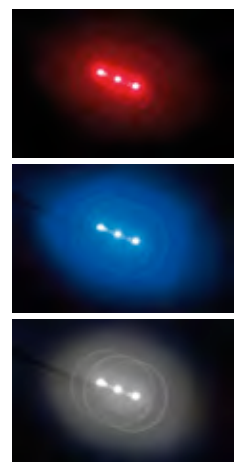

**HYPER-LED SET 5x3,  
STRISCE DECORATIVE A LED - 12V**

Per illuminazione interna o esterna. Doppio sistema di fissaggio: tramite adesivo speciale o con viti non incluse. Impermeabile

**HYPER-LED SET 5x3,  
LED DECORATION LIGHT - 12V**

For internal or external use. Double fixing system: with special adhesive or screws. Waterproof

<b>73527</b>		Rosso	Red
<b>73528</b>		Blu	Blue
<b>73529</b>		Bianco	White

D/Blister  5 / 20





**SPRAY-LITE - 12V**

Coppia spruzzatori per tergicristallo illuminati a led

**SPRAY-LITE - 12V**

Windscreen washers with led light (pair)

<b>70201</b>	Bianco	White
--------------	--------	-------

D/Blister 10 / 50



**MICRO-LITES SMALL - 12V**

Coppia microluci adesive misura piccola

**MICRO-LITES SMALL - 12V**

Pair of adhesive micro-lights, small size

<b>70212</b>	Bianco	White
<b>70217</b>	Blu	Blue
<b>70218</b>	Verde	Green

D/Blister 10 / 200



**LED LAMPEGGIANTE, SIMULATORE DI ANTIFURTO INSERITO, 12V**

Con filo per montaggio ad incasso.

**THEFT DETERRENT FLASHING LED LIGHT, 12V**

In-dash mount, complete with wires.

<b>70262</b>
--------------

D/Blister 10 / 100



**NIGHT SCANNER 12V**

Simulatore antifurto con 5 led ad accensione progressiva. Con interruttore, basso assorbimento

**NIGHT SCANNER 12V**

Alarm simulator, 5 red leds

<b>70259</b>
--------------

D/Blister 10 / 200



**SAFETY CAR STROBE LIGHT 12V**

Lampade stroboscopiche con centralina di controllo velocità e filtri colore

**STROBE LIGHT FOR CAR 12V**

With speed control and colour filters

<b>72908</b>
--------------

D/Blister 10 / 100

